



Alaska Railroad Corporation  
327 W. Ship Creek Avenue, Anchorage, AK 99501  
P.O. Box 107500, Anchorage, AK 99510-7500

September 27, 2019

## INVITATION TO BID (ITB) #19-38-307572

### CONCRETE BRIDGE SPANS AND CAPS

#### Response Required:

This page must be completed and returned to ensure receipt of future addenda or additional information. Fax this form to (907) 265-2439 or email to: [GoemerG@akrr.com](mailto:GoemerG@akrr.com). All addenda will be forwarded to the contact name and number listed below.

**Firms that have not returned the cover sheet will not be informed of addendums and will only be alerted to addendums by checking with the ARRC procurement officer or by checking ARRC's internet site: [www.akrr.com](http://www.akrr.com), select Suppliers and then Solicitations. Bidders must acknowledge the receipt of all issued addendums in their proposal/bid submittal.**

Company Name \_\_\_\_\_

Mailing Address \_\_\_\_\_

City, State, Zip \_\_\_\_\_

Contact Name \_\_\_\_\_

Phone Number \_\_\_\_\_ Fax \_\_\_\_\_

Email Address \_\_\_\_\_

The Alaska Railroad Corporation web site [www.alaskarailroad.com](http://www.alaskarailroad.com)

## INVITATION TO BID (ITB) #19-38-307572

### CONCRETE BRIDGE SPANS AND CAPS

THIS IS NOT AN ORDER

DATE ITB ISSUED: September 27, 2019

SEALED BIDS WILL BE RECEIVED AT:

Alaska Railroad Corporation  
327 West Ship Creek,  
Anchorage, Alaska 99501

UNTIL 3:00 P.M. LOCAL TIME ON OCTOBER 22, 2019, AT THAT  
TIME BIDS WILL BE PUBLICLY OPENED.

### CONCRETE BRIDGE SPANS AND CAPS

The Alaska Railroad Corporation (“ARRC”) is soliciting bids from interested parties to repaint and repair passenger coaches as specified herein. Interested parties are invited to submit a bid to supply said services to ARRC. Bids must be submitted on the bid form contained herein and must be mailed or delivered to the above address. Bids received via facsimile transmission will be considered non-responsive. The bid shall be in a sealed envelope with the bid number 19-38-30752 clearly printed on the face of the envelope. Bids must be complete and in U.S. dollars. See instructions and conditions enclosed herein.

ARRC reserves the right to reject any and all bids, or any part thereof, negotiate changes in bids, accept any bids or any part thereof, waive minor informalities or defects in any bids, and not to award the proposed contract if it is in the best interest of the ARRC.

ARRC shall not be held responsible for bidder’s lack of understanding of what is required by this bid. Should a bidder not understand any aspect of this bid, or require further explanation, or clarification regarding the intent or requirements of this bid, it shall be the responsibility of the bidder to seek guidance from the ARRC.

ARRC may award a contract resulting from this solicitation to the responsive offeror whose offer conforming to this solicitation will be the most advantageous to the ARRC. ARRC may reject any or all offers if such action is in the best interest of ARRC, and waives informalities and minor irregularities in offers received. Any resulting contract from this solicitation shall incorporate the Standard Instructions, and General Terms and Conditions incorporated in this solicitation.

This solicitation is not to be construed as a commitment of any kind nor does it commit the ARRC to pay for any costs incurred in the submission of an offer or for any other incurred cost prior to the execution of a formal contract

**BIDDER/VENDOR TERMS AND CONDITIONS: PROSPECTIVE BIDDERS ARE CAUTIONED TO PAY PARTICULAR ATTENTION TO THIS CLAUSE.** Bidder/contractor imposed terms and conditions which conflict with this Invitation to Bid terms and conditions are considered counter

offers and, as such, will cause the Alaska Railroad Corporation to consider the bid non-responsive.

If a bidder attaches additional terms and conditions as part of the bid, such attachments must be accompanied by a disclaimer stating that in the event of conflict between the terms and conditions of this Invitation to Bid and the terms and conditions of the bidder/contractor, the terms and conditions of the Invitation to Bid will prevail.

**Important:** Work associated with this bid may be funded in part by funds from the Federal Transit Administration (“FTA”), an operating administration of the United States Department of Transportation; the Federal Railroad Administration (FRA); and the Alaska Railroad Corporation (ARRC). This solicitation package contains some provisions that are designated as applicable to FTA, FRA, and ARRC funded projects, mixed funding. See appendix H

ARRC Disadvantaged Business Enterprise (DBE) Program: ARRC is an equal opportunity corporation that encourages the participation of DBEs as prime contractors and subcontractors on its contracts funded in whole or in part by the Federal Transit Administration (FTA) or the Federal Highway Administration (FHWA). The ARRC has a race neutral DBE Program and does not set DBE goals on individual solicitations. Nonetheless, the ARRC aspires to achieve an overall DBE participation of 3.0% in federal fiscal years 2019-2021 on contracts funded by agencies within the U.S. Department of Transportation. If this contract is funded in whole or in part by funds from the FTA or the FHWA, it is imperative that you consult the Federal Terms and Conditions portion of this solicitation.



The Alaska Railroad is a member of Green Star (<http://www.greenstarinc.org/>). ARRC earned an initial Green Star Award in 1994 and a Green Star Air Quality Award in 2007. The Alaska Railroad considers Green Star membership to be a positive business attribute, and regards a Green Star award as a tangible sign of an organization’s commitment to environmental stewardship and continual improvement within its operations.

Please direct all responses and/or questions concerning this invitation to bid to Greg Goemer, Alaska Railroad Corporation, Supply Management, 327 W. Ship Creek Avenue, Anchorage, AK 99501, telephone number 907-265-2593, email address [goemerg@akrr.com](mailto:goemerg@akrr.com). Questions must be submitted in written form prior to October 18, 2019. Questions submitted after that date may not be accepted.

Sincerely,

Greg Goemer  
Sr. Contract Administrator

## INDEX

- APPENDIX A: REQUIRED DOCUMENTS
- APPENDIX B: MINIMUM QUALIFICATIONS & PREFERENCES
- APPENDIX C: STANDARD INSTRUCTIONS AND CONDITIONS FOR THE SUBMISSION OF BIDS TO THE ALASKA RAILROAD CORPORATION
- APPENDIX D: SPECIFICIFICATIONS
- APPENDIX E: BIDDER'S QUESTIONNAIRE
- APPENDIX F: SUPPLY BID FORM 395-0132
- APPENDIX G: GENERAL TERMS AND CONDITIONS - SUPPLY
- APPENDIX H: COST SCHEDULE
- ATTACHMENT: PLAN SET (CONSISTS OF 15 PAGES)

## **APPENDIX A**

### **REQUIRED DOCUMENTS**

Bids must be submitted in the spaces provided on the Cost Schedule of this invitation in accordance with the conditions of bid as stated herein. The bid will not be considered to be complete unless all spaces have been filled in. Consideration for award will be provided to complete bids only. If a bidder wishes to supply additional information, it may be included along with the bid in the sealed bid envelope.

Bidder/contractor imposed terms and conditions which conflict with the terms and conditions of this Invitation to Bid are considered counter offers and, as such, will cause the Alaska Railroad Corporation to consider the bid non-responsive. If a bidder attaches additional terms and conditions as part of the bid, such attachments must be accompanied by a disclaimer stating that in the event of conflict between the terms and conditions of this Invitation to Bid and the terms and conditions of the bidder/contractor, the terms and conditions of the Invitation to Bid will prevail.

Bids will not be considered responsive if the following documents are not completely filled out and submitted at the time of the bidding:

1. Bidders Questionnaire [Form 395-0136]
2. Supply Bid Form - [Form 395-0132]
3. Cost Schedule

## APPENDIX B

### MINIMUM QUALIFICATIONS & PREFERENCES

1. ALASKA BIDDER PREFERENCE: Award will be made to the lowest responsive and responsible bidder after an Alaska bidder preference of five percent (5%) has been applied. The preference will be given to a person who: (1) holds a current Alaska business license at the time designated in the invitation to bid for bid opening; (2) submits a bid for goods or services under the name on the Alaska business license; (3) has maintained a place of business within the state staffed by the bidder, or an employee of the bidder, for a period of six months immediately preceding the date of the bid; (4) is incorporated or qualified to do business under the laws of the state, is a sole proprietorship and the proprietor is a resident of the state, is a limited liability company organized under AS 10.50 and all members are residents of the state, or is a partnership under AS 32.06 or AS 32.11 and all partners are residents of the state; and, (5) if a joint venture, is composed entirely of ventures that qualify under (1) - (4) of this subsection.

2. ALASKA VETERAN PREFERENCE: If a bidder qualifies for the Alaska bidder preference and is a qualifying entity as defined herein, they will be awarded an Alaska veteran preference of five percent (5%). The preference will be given to a (1) sole proprietorship owned by an Alaska veteran; (2) partnership under AS 32.06 or AS 32.11 if a majority of the partners are Alaska veterans; (3) limited liability company organized under AS 10.50 if a majority of the members are Alaska veterans; or (4) corporation that is wholly owned by individuals and a majority of the individuals are Alaska veterans, and may not exceed \$5,000. The bidder must also add value by actually performing, controlling, managing, and supervising the services provided, or for supplies, the bidder must have sold supplies of the general nature solicited to other state agencies, other governments, or the general public.

**In order to receive the Alaska Bidder Preference and/or Alaskan Veteran Preference, the bid must also include a statement certifying that the bidder is eligible to receive said preferences. The application of preferences is for bid evaluation purposes only.**

## APPENDIX C

### STANDARD INSTRUCTIONS AND CONDITIONS FOR THE SUBMISSION OF BIDS TO THE ALASKA RAILROAD CORPORATION

#### 1. Method of Bidding

Bids must be submitted in the spaces provided on the bid sheets of this invitation in accordance with the conditions of bid as stated herein. The bid will not be considered to be complete unless all spaces have been filled in. Consideration for award will be provided to complete bids only. If a Bidder wishes to supply additional information, it may be included along with the bid in the sealed bid envelope.

#### 2. Bidder's Terms and Conditions: Prospective bidders are cautioned to pay particular attention to this clause.

Bidder/Contractor imposed terms and conditions which conflict with this Invitation to Bid terms and conditions are considered counter offers and, as such, will cause the Alaska Railroad Corporation to consider the bid non-responsive.

If a Bidder attaches additional terms and conditions as part of the bid, such attachments must be accompanied by a disclaimer stating that in the event of conflict between the terms and conditions of this Invitation to Bid and the terms and conditions of the Bidder/Contractor, the terms and conditions of the Invitation to Bid will prevail.

#### 3. Amendments

The ARRC procurement officer will attempt to notify all who are known to have received the solicitation documents if any amendments are issued, but it shall be the bidder's responsibility to ascertain prior to submitting a bid that he/she has received all amendments issued.

#### 4. Submission of Bids

4.1 Interested vendors shall submit an original and one copy of their bids in sealed envelopes or packages (1) addressed to the office specified in the solicitation and (2) showing the time specified for receipt, the solicitation number, and the name and address of the bidder. Bids must be received by ARRC no later than the local time at the place and on the date set for receipt of bids in the solicitation.

4.2 Any required samples must be submitted within the time specified for receipt of bids. Unless otherwise specified in the solicitation, these samples shall be (1) submitted at no expense to the ARRC and (2) returned only upon the sender's request and at their expense.

4.3 ARRC may postpone the date and time announced for receipt of bids. Such postponement may be made at any time prior to the established date and time for receipt of bids by notice and addendum to the solicitation to all known potential bidders.

#### 5. Explanation to Prospective Bidders

Bidders shall promptly notify ARRC of any ambiguity, inconsistency, conflict, or error which they may discover upon examination of the solicitation documents. All inquiries regarding a solicitation shall be directed to the ARRC representative specified in the solicitation. Any prospective bidder desiring an explanation or interpretation of the solicitation, drawings, specifications, etc., must request it in writing soon enough to allow a reply to reach all prospective bidders before the submission of their bid. To facilitate the exchange of information, vendors' questions regarding a solicitation may be communicated by telephone, and then confirmed in writing. Oral explanations or instructions given before award of the contract will not be binding. Oral explanations or

instructions given to a prospective bidder concerning a solicitation will be furnished promptly to all other prospective bidders as an amendment to the solicitation, if in the opinion of ARRC, such information is deemed necessary to submit bids or if the lack of it would be prejudicial to other prospective bidders

## **6. Late Submissions, Modifications, and Withdrawals of Bids/Proposals**

6.1 Any bid received at the office designated in the solicitation after the exact time specified for receipt will not be considered unless the delay was due to an ARRC error.

6.2 The only acceptable evidence to establish the time of receipt at the ARRC is the time/date stamp of ARRC's Procurement Office on the bid wrapper or other documentary evidence of receipt maintained by ARRC.

6.3 Correction, modification, or withdrawal of bids will be allowed only as stated in ARRC Procurement Rule 1200.8.

## **7. Preparation of Bids/Proposals**

7.1 Bidders are expected to carefully examine the solicitation documents including all drawings, specifications, schedules, terms and conditions, and all instructions. Failure to do so will be at the bidder's risk. Incomplete bids may be rejected as nonresponsive.

7.2 Each bidder shall furnish all information required by the solicitation. An officer or other official of the vendor's company who has legal authority to commit the vendor to the contract proposed must sign the bid. The person signing the bid must initial erasures or other changes.

7.3 Bids for supplies or services other than those specified, or bids conditioned upon receiving award of all or a portion of the contract shall be deemed nonresponsive and shall be rejected unless authorized by the solicitation.

7.4 Time, if stated as a number of days, will include Saturdays, Sundays, and holidays.

## **8. Evaluation of Bids and Contract Award**

ARRC shall review and evaluate each submission in accordance with the criteria established in the solicitation and ARRC's Procurement Rules. In addition to other factors, bids will be evaluated on the basis of advantages and disadvantages to ARRC that might result from making more than one award (multiple awards).

## **9. Reservations**

In addition to other rights in the solicitation, ARRC reserves, holds and may exercise at its sole discretion, the following rights and options:

9.1 ARRC may reject any or all bids, or any part thereof, and may waive technicalities and minor informalities if such action is deemed to be in its best interest. ARRC also may reject the bid of any vendor who has previously failed to perform adequately under a prior contract for furnishing supplies/services to ARRC.

9.2 If an award is made and, prior to entering into a contract, subsequent information indicates that such award was not in the best interest of ARRC, ARRC may rescind the award without prior notice to bidders and either award to another bidder or reject all bids.

9.3 ARRC may cancel any contract, if in its opinion the vendor fails at any time to perform adequately, or if there is any attempt to willfully impose goods/services upon ARRC which are, in ARRC's opinion, of an unacceptable quality. Any action taken pursuant to this latter stipulation



shall not affect or impair any rights or claim of ARRC to damages for breach of any covenants of the contract by the vendor.

9.4 If the vendor fails to furnish any item or to complete the required work included in the contract, ARRC may withdraw such items or required work from the operation of the contract without incurring further liability.

9.5 ARRC may accept any item or group of items of a bid unless the bidder qualifies the bid by specific limitation.

9.6 ARRC may make an award on any item or quantities less than the quantity offered, at the unit cost or prices offered, unless the bidder specifies otherwise.

9.7 ARRC may supplement, amend, or otherwise modify or cancel this solicitation with or without substitution of another solicitation.

9.8 ARRC may conduct investigations of the bidders and their bids and request additional evidence or documentation to support the information included in any bid.

## **10. Aggrieved Bidder**

An aggrieved bidder may protest an ARRC procurement action by filing a written protest with the procurement officer in accordance with the procedures and time limits specified in ARRC Procurement Rules 1800.1-1800.11.

## **11. Incurred Costs**

The issuance of a solicitation does not obligate ARRC to pay for any bid preparation costs incurred by bidders and does not obligate ARRC to award a contract for supplies/services. All costs incurred as a result of a solicitation or contract negotiations resulting from a solicitation, including travel and personal expenses, are the sole responsibility of the bidder.

## **12. Availability of Funds**

The ARRC's obligation under any contract is contingent upon the availability of funds to pay for contract purchases. No legal liability on the part of ARRC may arise until funds are made available for a contract and until the Contractor receives written notice of such availability from the procurement officer. Signature by an authorized ARRC representative on the contract award document constitutes written notice of availability of funds.

## **13. Public Information**

All submitted bids will be considered confidential until notice of intent to award is issued. After notice of intent to award is issued, all bids will become public information.

## **14. Price**

ARRC shall receive the benefit of any general reduction in bidder's price prior to the delivery of supplies or services and in no event shall ARRC be charged higher prices than bidder's similar customers who purchase substantially similar supplies or services under substantially similar circumstances. All prices bid shall be exclusive of any federal, state, or local taxes from which ARRC is exempt.

## **APPENDIX D**

### **SPECIFICATIONS**

#### **General Project Description**

The Alaska Railroad Corporation is seeking the services of a qualified precast concrete fabricator experienced in the production of precast, prestressed concrete bridge elements. The bridge elements consist of standardized concrete spans and pile caps. This invitation to bid includes the standardized concrete spans and pile caps. It is the Alaska Railroad Corporation's intention to utilize these concrete spans for the construction of new ballasted deck bridges as a replacement for aging timber trestle structures where conditions are appropriate. An on-going timber trestle replacement program requiring additional units is anticipated, but not guaranteed.

#### **Scope of Work**

Contractor will be responsible for all materials, labor, equipment, services and supervision necessary for the manufacture of precast, prestressed concrete bridge spans in accordance with the project drawings, referenced publications, and this specification.

This contract includes the manufacture of twenty (20) each. Two (2) each make up one (1) concrete bridge span. Each span unit is comprised of two identical half-sets which mate longitudinally to form a complete span unit. With the exception of bar mark DN, and that required for loading and proper securing for shipment, the fabricator is not responsible for materials or items which are not embedded in, or cast with, the completed concrete section. Bar mark DN must be installed prior to handling and shipment.

This contract also includes sixteen (16) intermediate caps.

#### **Project Requirements**

The Alaska Railroad Corporation, or representative, shall have complete, unrestricted access to the fabrication site at all times when work is proceeding on the precast spans. The fabricator shall provide sufficient advance notice of operations to allow the Railroad to arrange for on-site inspection.

Concrete testing shall be performed by the fabricator, with all test records delivered to the Alaska Railroad. Representative samples for an air test, a slump test and a strength test, (from four molded test cylinders), shall be taken each day elements are cast. Test cylinders shall be carefully handled and cured in an identical manner to the bridge elements. Cylinders shall be tested per instructions of the Alaska Railroad Corporation.

Bidders must include firm delivery dates with their response. Units will be purchased FOB rail siding Anchorage, Alaska.

Fabrication tolerances are critical to proper mating of half-set sections. This and other quality control measures will be carefully checked prior to acceptance of precast units by the Alaska Railroad Corporation.

Payment shall be made based upon unit cost for each bridge span unit fabricated in accordance with the project drawings, referenced publications, and these specifications.

### **Project Drawings and Reference Material**

Alaska Railroad Standard "General Notes and Specifications"

Alaska Railroad Standard "Cross Section and Miscellaneous Details"

Alaska Railroad Standard "Prestressed Girder Details," Option "A"

Alaska Railroad Standard "Typical Precast Superstructure Details," Option "A"

**APPENDIX E**

QUESTIONNAIRE

Note: Failure to provide the information requested in this questionnaire may be cause for rejection of your bid or offer on the grounds of nonresponsiveness and/or nonresponsibility.

Solicitation Number \_\_\_\_\_

Business Name: \_\_\_\_\_

Street Address: \_\_\_\_\_

Mailing Address if Different: \_\_\_\_\_

City: \_\_\_\_\_ State: \_\_\_\_\_ Mailing Zip: \_\_\_\_\_

Telephone: \_\_\_\_\_ Fax: \_\_\_\_\_ E-Mail: \_\_\_\_\_

Date Firm Established: \_\_\_\_\_

How many years has the business been under the above name? \_\_\_\_\_

Previous business name(s)if any: \_\_\_\_\_

Federal Tax ID Number: \_\_\_\_\_

Business License Number: \_\_\_\_\_

Contractor License Number (For Construction: \_\_\_\_\_

Bid Acceptance Period \_\_\_\_\_ Days. (Bids providing less than thirty-day (30) calendar days for acceptance may be considered nonresponsive and may be rejected.)

Discount for prompt pay \_\_\_\_\_ % \_\_\_\_\_ days.

Veteran Owned Business \_\_\_\_\_ Disabled \_\_\_\_\_

List any variations from or exceptions to the Terms, Conditions or Specifications of the Solicitation

\_\_\_\_\_  
\_\_\_\_\_  
\_\_\_\_\_

*Continued on the next page*

List the three most recent contracts performed by your company where the commodity or service requested in this solicitation was the primary commodity or service supplied. Include the client's name, contract amount, the contract date, person to contact regarding performance, their telephone, facsimile number and e-mail.

Clients name, Contact person, Contact info. (telephone, and email)	Description of Work and Contract Amount
<u>List any other business related experience:</u>	

Are you acting as a broker or the primary supplier in this transaction?

- Broker
- Primary Supplier

Business Information (Please check all that apply):

- The business is Individual
- The business is a Partnership
- The business is a Non-Profit
- The business is a Joint-Venture
- The business is a Corporation incorporated under the laws of the State of \_\_\_\_\_
- The business is full-time
- The business is part-time
- The business is not a certified Disadvantaged Business (DBE)
- Business is a certified DBE
- DBE was certified by State DOTPF
- DBE was certified by the Municipality of Anchorage
- Business is an 8(a)/WBE/MBE and is certified by SBA
- B business was certified by \_\_\_\_\_
- DBE Certification # is \_\_\_\_\_

Firms Annual Gross Receipts:

- <\$500,000
- \$500,000 - \$999,999
- \$1,000,000 - \$4,999,999
- \$5,000,000 - \$9,999,999
- \$10,000,000 - \$16,999,999
- >\$17,000,000

Completed by: \_\_\_\_\_ Title: \_\_\_\_\_

Signature: \_\_\_\_\_ Date: \_\_\_\_\_

**APPENDIX F**

**ALASKA RAILROAD CORPORATION  
SUPPLY BID FORM**

**NAME** \_\_\_\_\_  
**ADDRESS** \_\_\_\_\_  
\_\_\_\_\_

**To the CONTRACTING OFFICER, ALASKA RAILROAD CORPORATION:**

In compliance with your Invitation for Bids No.: \_\_\_\_\_, dated \_\_\_\_\_, the Undersigned proposes to furnish and deliver all the supplies, materials or equipment and perform all the work required in said Invitation according to the specifications and requirements contained therein and for the amount and prices named herein as indicated on the Cost Schedule, which is made a part of this Bid.

The Undersigned hereby agrees to execute the said contract and bonds, if any, within **Ten (10) Calendar Days**, or such further time as may be allowed in writing by the Contracting Officer, after receiving notification of the acceptance of this Bid, and it is hereby mutually understood and agreed that in case the Undersigned does not, the accompanying bid guarantee, if any, shall be forfeited to the Alaska Railroad Corporation as liquidated damages, and said Contracting Officer may proceed to award the contract to others.

The Undersigned agrees to commence performance within **Ten (10) Calendar Days** after the effective date of the Notice to Proceed and to complete performance by \_\_\_\_\_, unless extended in writing by the Contracting Officer.

The Undersigned acknowledges receipt of the following addenda to the requirements and/or specifications for this Invitation for Bids (give number and date of each).

Addendum Number/Dated	Addendum Number/Dated	Addendum Number/Dated
_____	_____	_____
_____	_____	_____

**NON-COLLUSION AFFIDAVIT**

The Undersigned declares, under penalty of perjury under the laws of the United States, that neither he/she nor the firm, association, or corporation of which he/she is a member, has, either directly or indirectly, entered into any agreement, participated in any collusion, or otherwise taken any action in restraint of free competitive bidding in connection with this Bid.

\_\_\_\_\_

The Undersigned has read the foregoing proposal and hereby agrees to the conditions stated therein by affixing his/her signature below:

Name and Title of Person Signing _____	Signature _____
Telephone Number _____	E-mail Address _____ Form 395-0132

## APPENDIX G

### GENERAL TERMS AND CONDITIONS

The following terms and conditions supersede the terms and conditions on the reverse side of ARRC's purchase order to the extent that they are inconsistent therewith and shall be deemed to have the same force and effect as though expressly stated in any such purchase order into which this document is incorporated.

1. Definitions.

"ARRC" shall mean the Alaska Railroad Corporation.

"Vendor" shall mean the person or entity entering into the contract to provide the supplies specified therein for ARRC.

"Contract" shall mean these General Terms and Conditions, the contract form to which they are annexed, and all other terms, conditions, schedules, appendices or other documents attached to the contract form or incorporated by reference therein.

"Supplies" shall mean the equipment, goods, materials or other items to be provided by Vendor to ARRC under the contract.

2. Inspection and Reports. ARRC may inspect all of the Vendor's facilities and activities under this contract in accordance with the provisions of ARRC Procurement Rule 1600.9. The Vendor shall make progress and other reports in the manner and at the times ARRC reasonably requires.

3. Claims. Any claim by Vendor for additional compensation or equitable adjustment arising under this contract which is not disposed of by mutual agreement must be made by Vendor in accordance with the time limits and procedures specified in sections 1800.12 et seq. of ARRC's Procurement Rules, which by this reference are hereby incorporated herein.

4. Nondiscrimination.

4.1 The Vendor may not discriminate against any employee or applicant for employment because of race, religion, color, national origin, ancestry, physical or mental handicap, sex, marital status, change in marital status, pregnancy or parenthood when the reasonable demands of the positions do not require distinction on the basis of age, physical handicap, sex, marital status, changes in marital status, pregnancy, or parenthood. To the extent required by law, the Vendor shall take affirmative action to insure that the applicants are considered for employment and that employees are treated during employment without unlawful regard to their race, color, religion, national origin, ancestry, physical or mental handicap, age, sex, marital status, changes in marital status, pregnancy or parenthood. This action must include, but need not be limited to, the following: employment, upgrading, demotion, transfer, recruitment or recruitment advertising, layoff or termination, rates of pay or other forms of compensation, and selection for training including apprenticeship. The Vendor shall post in conspicuous places,

available to employees and applicants for employment, notices setting out the provisions of this paragraph.

4.2 The Vendor shall cooperate fully with ARRC efforts which seek to deal with the problem of unlawful discrimination, and with all other ARRC efforts to guarantee fair employment practices under this contract, and promptly comply with all requests and directions from the State Commission for Human Rights or any of its officers or agents relating to prevention of discriminatory employment practices.

4.3 Full cooperation in Paragraph 4.2 includes, but is not limited to, being a witness in any proceeding involving questions of unlawful discrimination if that is requested by any official or agency of the State of Alaska; permitting employees of the Vendor to be witnesses or complainants in any proceeding involving questions of unlawful discrimination, if that is requested by any official or agency of the State of Alaska; participating in meetings; submitting periodic reports on the equal employment aspects of present and future employment; assisting inspection of the Vendor's facilities; and promptly complying with all State directives considered essential by any office or agency of the State of Alaska to insure compliance with all federal and state laws, regulations, and policies pertaining to the prevention of discriminatory employment practices.

4.4 Failure to perform under this section constitutes a material breach of the contract.

5. Cancellation/Termination.

5.1 ARRC may, for its sole convenience, cancel this contract in whole or in part, at any time by giving written notice of its intention to do so. In the event of such cancellation, Vendor shall be entitled to receive payment in accordance with the payment provisions of this contract for supplies delivered to ARRC and, as to work in progress prior to receipt of notice, ARRC shall pay Vendor only for direct expenditures on work specifically identified to this contract. Vendor shall not be paid for any work done after receipt of a notice of cancellation or for any costs incurred by Vendor's suppliers or subcontractors which Vendor could reasonably have avoided. However, in no event shall ARRC be liable for incidental, consequential, or punitive damages, overhead or other direct or indirect costs, or lost profits. Payments made under this contract shall not exceed the aggregate price specified in this contract.

5.2 In addition to ARRC's right to cancel this contract for its convenience, ARRC may, by written notice of default to Vendor, terminate the contract in whole or in part in the following circumstances:

(1) The Vendor refuses or fails to perform its obligations under the contract, or fails to make progress so as to significantly endanger timely completion or performance of the contract in accordance with its terms, and Vendor does not cure such default within a period of ten (10) days after receipt of written notice of default from ARRC or within such additional cure period as ARRC may authorize; or

(2) Reasonable grounds for insecurity arise with respect to Vendor's expected performance and Vendor fails to furnish adequate assurance of due performance (including assurance of performance in accordance with the time requirements of the contract) within ten (10) days after receipt of a written request by ARRC for adequate assurance; or



(3) Vendor becomes insolvent or makes an assignment for the benefit of creditors or commits an act of bankruptcy or files or has filed against it a petition in bankruptcy or reorganization proceedings.

5.3 Upon receipt of a notice of cancellation or termination, Vendor shall immediately discontinue all work and it shall immediately cause any of its suppliers or subcontractors to cease such work unless the notice directs otherwise. In the event of termination for default, Vendor shall be liable for any damage to ARRC resulting from the Vendor's nonperformance. The rights and remedies of ARRC provided in this section shall not be exclusive and are in addition to any other rights and remedies provided by law.

6. No Assignment or Delegation. The Vendor may not assign, subcontract or delegate this contract, or any part of it, or any right to any of the money to be paid under it, except with the prior written consent of ARRC. No such approval shall relieve Vendor from any of its obligations or liabilities under this contract.

7. Independent Contractor. The Vendor's relationship to ARRC in performing this contract is that of an independent contractor and nothing herein shall be construed as creating an employer/employee relationship, partnership, joint venture or other business group or concerted action.

8. Payment of Taxes. As a condition of performance of this contract, the Vendor shall pay all federal, state, and local taxes incurred by the Vendor and shall require their payment by any subcontractor or any other persons in the performance of this contract. Satisfactory performance of this paragraph is a condition precedent to payment by ARRC under this contract.

9. Governing Law. This contract, and all questions concerning the capacity of the parties, execution, validity (or invalidity) and performance of this contract, shall be interpreted, construed and enforced in all respects in accordance with the laws of the State of Alaska.

10. Alaska Executive Branch Ethics Act Requirements. No officer or employee of the State of Alaska or of the ARRC and no director of the ARRC or legislator of the state shall be admitted to any share or part of this contract or to any benefit that may arise therefrom. Vendor shall exercise reasonable care and diligence to prevent any actions or conditions which could be a violation of Alaska Statute 39.52 et seq. Vendor shall not make or receive any payments, gifts, favors, entertainment, trips, secret commissions, or hidden gratuities for the purpose of securing preferential treatment or action from or to any party. This obligation will apply to the activities of Vendor's employees and agents in their relations with ARRC employees, their families, vendors, subcontractors, and third parties arising from this contract and in accomplishing work hereunder. Certain gratuities may be given or accepted if:

- (1) there is no violation of any law or generally accepted ethical standards;
- (2) the gratuity is given as a courtesy for a courtesy received and does not result in any preferential treatment or action;
- (3) the gratuity is of limited value (less than \$150) and could not be construed as a bribe, payoff or deal; and
- (4) public disclosure would not embarrass ARRC.

ARRC may cancel this contract without penalty or obligation in the event Vendor or its employees violate the provisions of this section.

11. Covenant Against Contingent Fees. Vendor warrants that it has not employed or retained any company or person, other than a bona fide employee working solely for Vendor, to solicit or secure this contract, and that it has not paid or agreed to pay any person, company, individual, or firm any commission, gift, percentage, fee, contingent upon or resulting from the award or making of this contract. For the breach or violation of this warranty, ARRC may terminate this contract without liability and, at its discretion, deduct from the contract price or otherwise recover the full amount of the commission, percentage, gift, or fee.

12. Warranty. Vendor warrants that the equipment, goods, materials or other supplies sold to ARRC under this contract: (a) shall be of good quality and free from all defects and deficiencies in workmanship, material and design; (b) shall be fit, suitable and operate successfully for their intended purpose; (c) shall be new; (d) shall be free from all liens, claims, demands, encumbrances and other defects in title; and (e) shall conform to the specifications, if any, stated in the contract. Vendor shall honor all guarantees and warranties offered by the manufacturer of the equipment, goods, materials or other supplies provided under this contract.

The rights and remedies provided for in this section are in addition to any other remedies provided by law.

13. Indemnification. The Vendor shall indemnify, save harmless and defend ARRC, its officers, agents and employees from all liability of any nature or kind, including costs and expenses, for all actions or claims resulting from injuries or damages sustained by any person or property arising directly or indirectly as a result of any error, omission, product defect, negligent or wrongful acts of the Vendor, its subcontractors or anyone directly or indirectly employed by them in the performance of this contract, provided that Vendor's aforesaid indemnity and hold harmless agreement shall not be applicable to any liability based upon the sole negligence of ARRC.

14. ARRC's Rights Not Waived by Payment. No payment made by ARRC shall be considered as acceptance of satisfactory performance of Vendor's obligations under this contract. Nor shall any payment be construed as acceptance of substandard or defective work or as relieving Vendor from its full responsibility under the contract.

15. Nonwaiver. A party's failure or delay to insist upon strict performance of any of the provisions of this contract, to exercise any rights or remedies provided by this contract or by law, or to notify the other party of any breach of or default under this contract shall not release or relieve the breaching or defaulting party from any of its obligations or warranties under this contract and shall not be deemed a waiver of any right to insist upon strict performance of this contract or any of the rights or remedies as to any subject matter contained herein; nor shall any purported oral modification or rescission of this contract operate as a waiver of any of the provisions of this contract. The rights and remedies set forth in any provision of this Agreement are in addition to any other rights or remedies afforded the nonbreaching or nondefaulting party by any other provisions of this contract, or by law.

16. Savings Clause. If any one or more of the provisions contained in this contract shall, for any reason, be held to be invalid, illegal or unenforceable in any respect, such invalidity, illegality or unenforceability shall not affect any other provisions of this contract, but this contract shall be construed as if such invalid, illegal or unenforceable provision had never been contained herein.

17. Headings. The headings of sections and paragraphs of this contract are for convenience of reference only and are not intended to restrict, affect, or be of any weight in the interpretation or construction of the provisions of such sections or paragraphs.

18. Forum Selection. The parties shall not commence or prosecute any suit, proceeding or claim to enforce the provisions of the contract, to recover damages for breach or default under the contract, or otherwise arising under or by reason of the contract, other than in the courts of the State of Alaska for the Third Judicial District at Anchorage. The parties hereby irrevocably consent to the jurisdiction of said courts.

19. Conflict of Interest. Vendor shall act to prevent any actions or conditions which could result in a conflict with ARRC's best interests. This obligation shall apply to the activities of Vendor's employees and agents in their relationships with ARRC's employees, their families, vendors, subcontractors and third parties accomplishing work under this contract.

20. Publicity. Vendor shall not release any information for publication or advertising purposes relative to this contract or to the material, equipment and other supplies furnished under this contract without the prior written consent of the ARRC.

21. Audit. ARRC has the right to audit at reasonable times the accounts and books of the Vendor in accordance with the provisions of ARRC Procurement Rule 1600.10.

22. Internal Controls and Record Keeping. Vendor shall keep full and accurate records and accounts of all of its activities in connection with this contract, including, without limitation, reasonable substantiation of all expenses incurred and all property acquired hereunder.

23. Force Majeure. Neither ARRC nor Vendor shall be responsible for failure to perform the terms of this contract when performance is prevented by force majeure, provided that: (1) notice and reasonably detailed particulars are given to the other party and (2) the cause of such failure or omission is remedied so far as possible with reasonable dispatch. The term "force majeure" shall mean acts of God, earthquakes, fire, flood, war, civil disturbances, governmentally imposed rules, regulations or other causes whatsoever, whether similar or dissimilar to the causes herein enumerated, which is not within the reasonable control of either party and which through the exercise of due diligence, a party is unable to foresee or overcome. In no event shall force majeure include normal or reasonably foreseeable or reasonably avoidable operational delays.

24. Set Off. If ARRC has any claim against the Vendor related or unrelated to this contract, it may set off the amount of such claim against any amount due or becoming due under this contract.

25. Observance of Rules. The Vendor's personnel performing work hereunder on ARRC's premises shall observe all fire prevention, security, and safety rules in force at the site of the work.

26. No Third-Party Beneficiary Rights. No provision of this contract shall in any way inure to the benefit of any third parties (including the public at large) so as to constitute any such person a third-party beneficiary of the contract or of any one or more of the terms hereof, or otherwise give rise to any cause of action in any person not a party hereto.

27. Entire Agreement. This contract represents the entire and integrated agreement between ARRC and the Vendor and supersedes all prior negotiations, representations, or agreements,

either written or oral. This contract may be amended only by a written instrument signed by both ARRC and the Vendor.

28. Invalid Provision. The invalidity or unenforceability of any provision of this contract shall not affect the other provisions hereof, and this contract shall be construed in all respects as if such invalid or enforceable provisions were omitted.

29. Packing, Marking and Shipping. All supplies shall be properly packaged to prevent damage or deterioration and to obtain the lowest transportation rates. ARRC will pay no charge for preparation, crating, dunnage or other materials unless separately stated in this contract. Each packing slip, bill of lading, invoice, container, tag and correspondence shall bear the applicable contract number and the location to which the supplies are to be shipped. A waterproof Master Packing Slip shall accompany each shipment and shall be included in one of the packages marked "Packing Slip Inside" or in the case of a carload shipment, be conspicuously displayed on the inside of the freight car. The original Bill of Lading shall be mailed to the attention of ARRC Supply Management Department on date of shipment.

30. Improper Delivery. If for any reason the Contractor fails to make timely delivery, ARRC may, at its option, approve a revised delivery schedule, request shipment via air or expedited routing (at Contractor's expense) or terminate this contract without any liability. Contractor will not, however, be liable for damages resulting from delays in delivery due to causes beyond Contractor's reasonable control, provided Contractor promptly notifies ARRC in writing of any such delay or expected delay as soon as such delay or expected delay becomes or should have become apparent. The remedies provided in this paragraph shall be cumulative and in addition to any other or further remedies ARRC may have.

31. Shipping Release. The Contractor shall not ship any of the supplies covered by this contract, unless specific delivery dates or written instructions are furnished to Contractor by ARRC. ARRC shall have no responsibility for supplies for which delivery dates or other written instructions have not been provided. Shipments in excess of those authorized may be returned to Contractor and Contractor shall pay ARRC for all expenses incurred in connection with such shipments. ARRC may change or temporarily suspend shipping schedules specified in this contract or written instructions.

32. Inspection/Rejection. Notwithstanding prior shipment, all supplies are subject to inspection and acceptance by ARRC within a reasonable time after they arrive at destination. ARRC shall notify Contractor if any supplies are rejected for any reason or if there are shortages. At ARRC's election, rejected supplies may be held for Contractor's account or returned to Contractor at Contractor's risk and expense. No replacement or correction of defective or nonconforming supplies shall be made by Contractor without written authorization from ARRC. Contractor shall promptly ship any shortages after notification of the same by ARRC.

33. Compliance with Laws and Regulations. Contractor agrees that in the performance of this contract it will comply with the requirements of all applicable Federal, State and local statutes, regulations and orders and will indemnify and save ARRC harmless from any claim, loss or damage arising from Contractor's violation or alleged violation of them.

34. Reduction in Contractor's Cost. Any reduction in Contractor's costs resulting from a reduction in freight rates, custom duties, import taxes, excise taxes and/or sales taxes from those in force on the date of the contract is to be paid to ARRC by Contractor in reduction of the price of the ordered supplies.

35. Payments. Payments for supplies furnished under this contract will be due thirty (30) days after the later of (1) receipt of the supplies established in the contract, (2) receipt of proper billing for such supplies, and (3) receipt of all documents required by this contract. ARRC shall not be liable for interest charges on late payments.

**APPENDIX H**  
**COST SCHEDULE**

A bidder's failure to provide the information requested in this appendix will be cause for rejection of the bid on the basis of non-responsiveness. All bids submitted in response to this solicitation must be signed by an individual with the legal authority to submit the bid on behalf of the company.

All items offered must be from the manufacture listed below.

**All prices listed are FOB Anchorage, Alaska.**

<u>Description</u>	<u>Quantity</u>	<u>Price</u>	
Provide precast concrete bridge spans units in accordance with the specification in (Appendix B.) Scope of Work. Eight (8) each ½ set makes Four (4) spans required. 2 each Half spans = 1 set	<b>20 Each</b>	\$ _____ Each	\$ _____ Total
Intermediate Caps	<b>16 Each</b>	\$ _____ Each	\$ _____ Total
			\$ _____ Total

**DELIVERY DATE:** Your bid should indicate the earliest firm delivery date after receipt of award. ARRC shall fully expect the successful contractor to completely satisfy contract performance requirements in accordance with firm delivery date offered in the Cost Schedule.

**Please indicate the earliest possible delivery date after receipt of order:**

\_\_\_\_\_ **Weeks ARO.**

**AWARD CRITERIA:**

An award of a contract will be made to the low, responsive, responsible bidder that meets the requirements as set forth in the specifications and compliance thereof. The Alaska Railroad Corporation reserves the right to determine that all offered materials will serve the application intended. Award will be made in the aggregate or by line item, whichever is deemed, by the Contract Administrator to be in the best interest of the ARRC. This may result in multiple awards. The bid award is contingent on the availability of Alaska Railroad Corporation funds.

**NON-COLLUSION AFFIDAVIT**

The Undersigned declares, under penalty of perjury under the laws of the United States, that neither he/she nor the firm, association, or corporation of which he/she is a member, has, either directly or indirectly, entered into any agreement, participated in any collusion, or otherwise taken any action in restraint of free competitive bidding in connection with this Bid.

The Undersigned has read the foregoing proposal and hereby agrees to the conditions stated therein by affixing his/her signature below:

\_\_\_\_\_  
Signature

\_\_\_\_\_  
Name and Title of Person Signing

\_\_\_\_\_  
Telephone Number

\_\_\_\_\_  
Email Address

(Page 2/2)

Form 395-0121 (12/99)

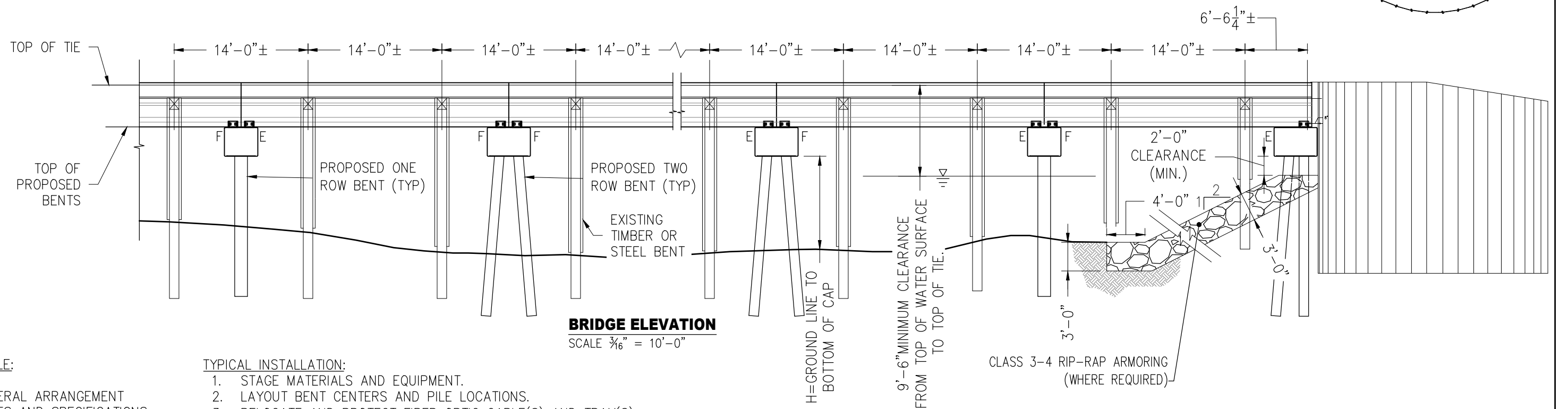
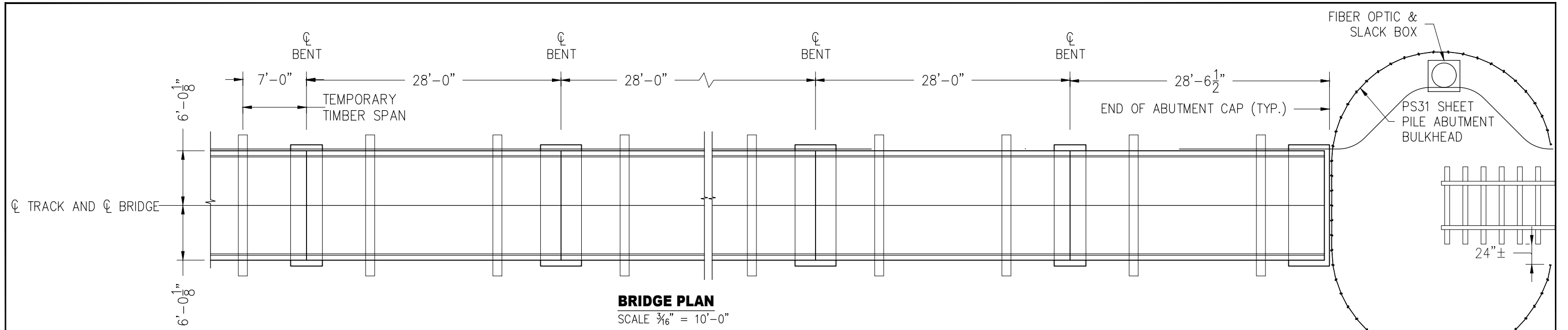

**SHEET TITLE:**

1. GENERAL ARRANGEMENT
2. NOTES AND SPECIFICATIONS
3. GIRDER TO CAP CONNECTION
4. PRESTRESSED GIRDER
5. PRECAST SUPERSTRUCTURE
6. PRECAST SUPERSTRUCTURE
7. FOUR PILE, SINGLE ROW BENT
8. THREE PILE, SINGLE ROW BENT
9. SINGLE ROW CAP
10. TWO ROW BENT
11. TWO ROW ABUTMENT
12. TWO ROW CAP
13. PIPE PILE DETAILS
14. TANGENT DIAPHRAGM
15. CURVE DIAPHRAGM

**TYPICAL INSTALLATION:**

1. STAGE MATERIALS AND EQUIPMENT.
2. LAYOUT BENT CENTERS AND PILE LOCATIONS.
3. RELOCATE AND PROTECT FIBER OPTIC CABLE(S) AND TRAY(S).
4. DRIVE PILES FOR ABUTMENTS AND INTERMEDIATE BENTS.
5. MARK AND CUT OFF PILING AT MINUS 7'-6" FROM TOP OF TIE.
6. FILL PILING WITH CONCRETE.
7. SET AND WELD CAPS.
8. STAGE CBD SECTIONS ALONGSIDE TRACK NEAR INSTALLATION ON DUNNAGE.
9. REPLACE BRIDGE TIES WITH MAINLINE TIES ON TRESTLE.
10. JACK AND SUPPORT TRACK NORTH AND SOUTH OF FIRST NEW SPAN LOCATION.
11. REMOVE TIMBER CHORDS AND PILE BENTS. DISPOSE OF WASTE AT APPROVED LOCATION. CUT OFF TIMBER PILES AT MUDLINE THAT CANNOT BE COMPLETELY EXTRACTED.
12. PICK AND SET CBD SECTIONS ONTO TEMPORARY PLYWOOD PADS USING STEEL TEES TO HOLD SPACE BETWEEN SECTIONS.
13. BOLT SECTIONS TOGETHER AT DIAPHRAGMS, PICK INDIVIDUAL CORNERS, REMOVING PLYWOOD AND INSTALLING ELASTOMERIC BEARING PADS.
14. INSTALL ANCHOR BRACKETS AND BOLTS. USE LOW TEMPERATURE GROUT IF BELOW 40°F.
15. INSTALL TEMPORARY BULKHEAD BOARD AT TRESTLE ENDS.
16. PLACE BALLAST. TAMP AND LINE TRACK.
17. REMOVE NEXT OR REMAINING 28 FOOT CHORDS AND BENTS.
18. REPEAT STEPS 12 THROUGH 17 AS REQUIRED.
19. DRIVE SHEET PILE BULKHEADS AND INSTALL ABUTMENT CLOSURE PLATES.
20. REPLACE FIBER OPTIC CABLE(S) AND TRAY(S) ONTO NEW SPANS.
21. FILL AND REMOVE REMAINING TIMBER TRESTLE. DIRECT-BURY FIBER OPTIC CABLE(S).
22. VEGETATE DISTURBED SLOPES USING APPROVED SEED MIX.
23. DEMOBILIZE.

<b>ALASKA RAILROAD CORPORATION</b> ENGINEERING SERVICES <small>P.O. BOX 107500, ANCHORAGE, ALASKA 99510-7500</small>		
PROJECT :		
<b>STANDARD 28 FOOT SPAN CONCRETE BALLAST DECK (CBD)</b>		
TITLE:		
<b>GENERAL ARRANGEMENT PLAN, ELEVATION AND NOTES</b>		
DESIGNED BY: ARRC	SCALE : AS NOTED	A/E NO.:
DRAWN BY: ARRC	DATE : FEB 2019	ACAD FILE:
CHECKED BY: CDR		DWG NO.
APPROVED BY: BAL		<b>1</b> OF <b>15</b>



GENERAL NOTES:

THIS STANDARD WAS DESIGNED IN ACCORDANCE WITH THE 1997 EDITION OF AREA (AREMA) SPECIFICATIONS CHAPTER 8 – CONCRETE STRUCTURES AND FOUNDATIONS AND CHAPTER 15 – STEEL STRUCTURES.

ALL METALWORK HARDWARE, UNLESS OTHERWISE NOTED SHALL BE HOT DIP GALVANIZED.

MAIN TRACK BALLAST TO BE FURNISHED SHALL CONFORM TO THE SPECIFICATIONS DETAILED IN THE CURRENT EDITION OF THE AREMA SPECIFICATIONS CHAPTER 2, "BALLAST".

BRIDGE DRAINAGE SYSTEM PIPE SHALL BE 3"Ø, SCHEDULE 80, PVC.

ALL DIMENSIONS SHOWN ON THE PLANS ARE TRUE HORIZONTAL AND TRUE VERTICAL AT 68°F NORMAL TEMPERATURE.

THE LOADS DESCRIBED AS FOLLOWS ARE COMBINED AS REQUIRED BY AREA (AREMA) SERVICE LOAD DESIGN.

- DL = DEAD LOAD OF COMPLETE STRUCTURE WITH 14" MAXIMUM BALLAST DEPTH.
- LL = LIVE LOAD, COOPER E-80. E-80 ALTERNATE LIVE LOAD IS NOT CONSIDERED.
- I = IMPACT FOR DIESEL LOCOMOTIVES.
- W = WIND ON 30 PSF ON LOADED BRIDGE AND 50 PSF ON UNLOADED BRIDGE.
- WL = WIND ON LIVE LOAD OF 300 PLF.
- LF = LONGITUDINAL FORCE FROM LIVE LOAD.
- E = EARTH PRESSURE FORCE.
- EQ = EARTHQUAKE LOAD BASED ON 1997 AASHTO INTERIM SPECIFICATIONS, AN ACCELERATION COEFFICIENT OF 0.25 WITH RETURN PERIOD OF 100 YEARS AND SOIL PROFILE TYPE I OR II.

SPECIFICATIONS FOR STRUCTURAL STEEL:

STRUCTURAL STEEL TO BE ASTM A36.

STEEL PIPE PILES FOR BENT SHALL BE 12"Ø OR 16"Ø X ½" WALL THICKNESS. DEPTH OF PILES TO BE DETERMINED BY PROJECT ENGINEER IN ACCORDANCE WITH PLAN DESIGN LOADS.

SPECIFICATIONS FOR BEARING PAD:

BEARING PAD MATERIAL SHALL BE LAMINATED ELASTOMER MADE OF NATURAL RUBBER HAVING A 60 DUROMETER HARDNESS, CONFORMING TO GRADE 5 OF THE CURRENT AASHTO SPECIFICATIONS.

SPECIFICATIONS FOR PRECAST AND PRESTRESSED CONCRETE:

CONCRETE:

CONCRETE MATERIAL, PLACING AND CURING TO BE PER CURRENT AREMA SPECIFICATIONS, CHAPTER 8 – CONCRETE STRUCTURES AND FOUNDATIONS.

COMPRESSIVE STRENGTH OF THE PRESTRESSED CONCRETE SHALL EXCEED 6,000 PSI AT 28 DAYS AND 4,500 PSI AT THE TRANSFER OF THE PRESTRESSING FORCE.

COMPRESSIVE STRENGTH OF THE REINFORCED CONCRETE SHALL EXCEED 4,000 PSI AT 28 DAYS, UNLESS OTHERWISE NOTED.

COPIES OF THE CONCRETE MIX DESIGN SHALL BE SUBMITTED TO ALASKA RAILROAD FOR APPROVAL BY THE CHIEF ENGINEER PRIOR TO THE START OF THE CASTING OPERATION.

PRESTRESSING STRAND:

ALL PRESTRESSING STRANDS SHALL BE ½ INCH DIAMETER, SEVEN WIRE, UNCOATED, LOW RELAXATION WITH A MINIMUM F'S=270 KSI AND MEET THE REQUIREMENTS OF ASTM A-416 SPECIFICATIONS. INITIAL PRESTRESS SHALL BE 0.75F'S=30,983 LBS. PER STRAND.

REINFORCING STEEL:

REINFORCING STEEL TO BE DEFORMED NEW BILLET BARS PER CURRENT ASTM A-615 SPECIFICATIONS AND TO MEET GRADE 60 REQUIREMENTS.

FABRICATION OF REINFORCING STEEL SHALL BE PER CHAPTER 7 OF THE CRSI MANUAL OF STANDARD PRACTICE. DIMENSIONS OF BENDING DETAILS ARE OUT TO OUT OF BAR.

REINFORCING STEEL IS TO BE BLOCKED TO PROPER LOCATION AND SECURELY WIRED AGAINST DISPLACEMENT. TACK WELDING OF REINFORCING IS PROHIBITED. MINIMUM CONCRETE COVER ON REINFORCEMENT SHALL MEET CURRENT AREMA SPECIFICATIONS.

MANUFACTURE:

EXPOSED SURFACES ARE TO BE FORMED IN A MANNER WHICH WILL PRODUCE A SMOOTH AND UNIFORM APPEARANCE WITHOUT RUBBING OR PLASTERING. EXPOSED EDGES OF 90 DEGREES OR LESS ARE TO EITHER CHAMFERED ¾ INCH BY ¾ INCH OR FINISHED TO A ROUNDED EDGE.

THE AREA AROUND ALL LIFTING LOOPS SHALL BE RECESSED SO THAT THE LOOPS CAN BE REMOVED TO A DEPTH OF ¾ INCH AND GROUTED.

FABRICATOR SHALL BE RESPONSIBLE FOR DEVELOPING LIFTING LOOP ANCHORAGE DETAILS TO PROVIDE SAFETY FACTOR OF 4 ON WORKING LOAD. LIFTING LOOP MUST BE HOT DIP GALVANIZED. DETAIL SHALL BE PROOF-TESTED WITH TEST RESULTS PROVIDED TO ALASKA RAILROAD.

PRODUCTION PROCEDURES FOR THE MANUFACTURE OF PRECAST, PRESTRESSED MEMBERS SHALL BE IN ACCORDANCE WITH THE PRESTRESSED CONCRETE INSTITUTE'S MANUAL OF MNL 116-77 FOR QUALITY CONTROL AND IN ACCORDANCE WITH THE CURRENT AREMA SPECIFICATIONS, CHAPTER 8.

ENDS OF THE STRANDS SHALL BE BURNED OFF AND RECESSED TO A DEPTH OF 1 INCH. SUCH RECESSED AND MINOR CONCRETE SPALLS SHALL BE FILLED AND FINISHED TO THE PLAN DIMENSIONS USING AN EPOXY BONDING COMPOUND AND GROUT.

CONTRACTOR SHALL SUBMIT SHOP DRAWINGS FOR PRESTRESSED GIRDERS TO ALASKA RAILROAD FOR APPROVAL PRIOR TO FABRICATION.

FABRICATOR SHALL BE RESPONSIBLE FOR LOADING AND PROPERLY SECURING ALL PRECAST CONCRETE MEMBERS FOR SHIPMENT TO RAILROAD SIDING, ALL CONCRETE COMPONENTS SHALL BE INSPECTED BY ALASKA RAILROAD AT THE FABRICATOR'S PLANT BEFORE SHIPMENT.

FABRICATOR TO MARK EACH PIECE WITH BRIDGE NUMBER AND PIECE MARK.

 <b>ALASKA RAILROAD CORPORATION</b> ENGINEERING SERVICES P.O. BOX 107500, ANCHORAGE, ALASKA 99510-7500		
PROJECT :		
<b>STANDARD 28 FOOT SPAN CONCRETE BALLAST DECK (CBD)</b>		
TITLE:		
<b>NOTES AND SPECIFICATIONS</b>		
DESIGNED BY: FC	SCALE : AS NOTED	AFE NO.:
DRAWN BY: ARRC	DATE : FEB/2019	ACAD FILE:
CHECKED BY: CDR		DWG NO. <b>2</b> OF <b>15</b>
APPROVED BY: BAL		

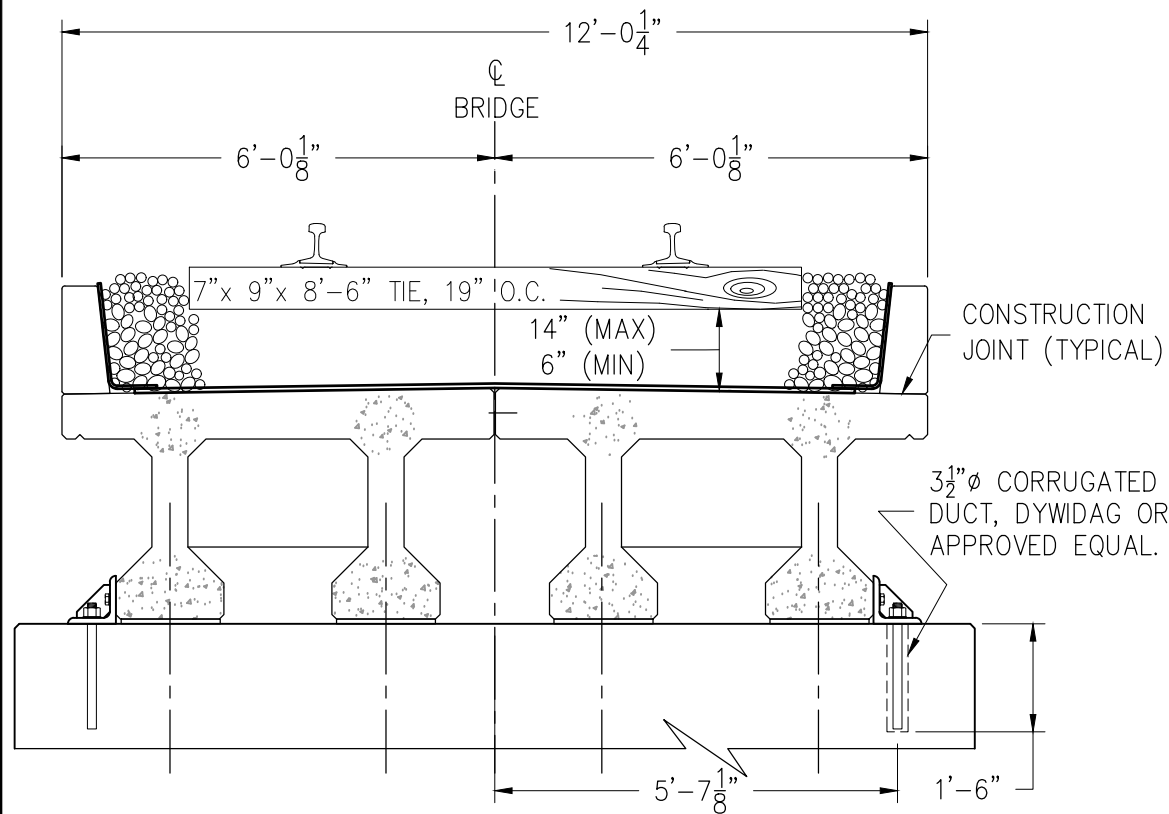

**CROSS SECTION AT CAP**

SCALE 3/8" = 1'-0"

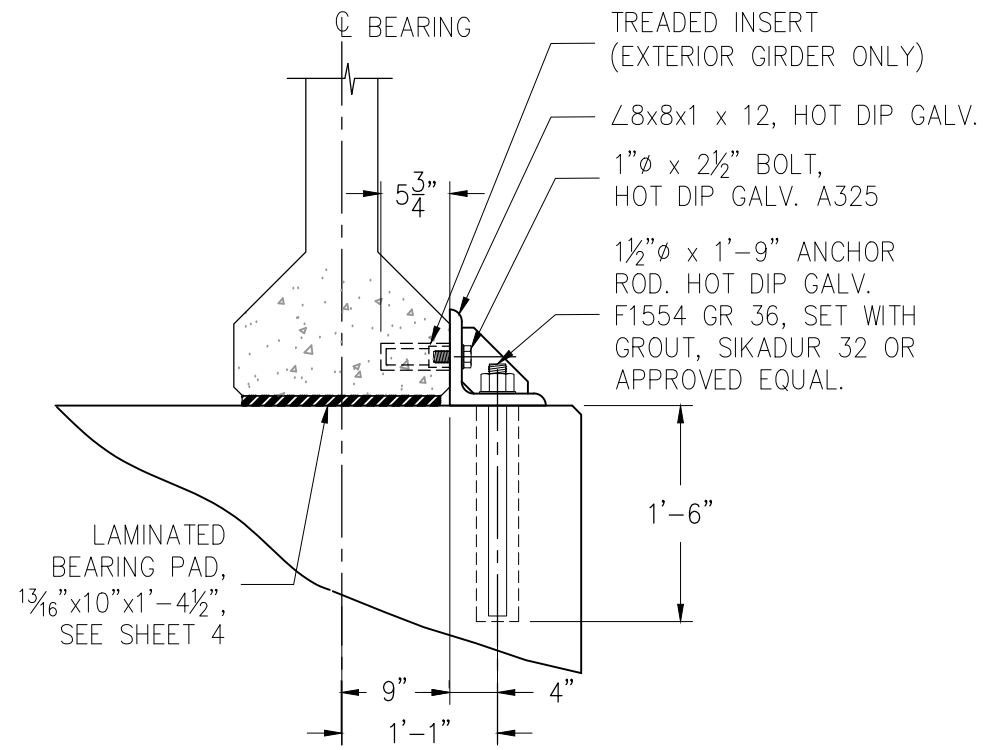

**TYPICAL GIRDER END VIEW**

SCALE 3/4" = 1'-0"

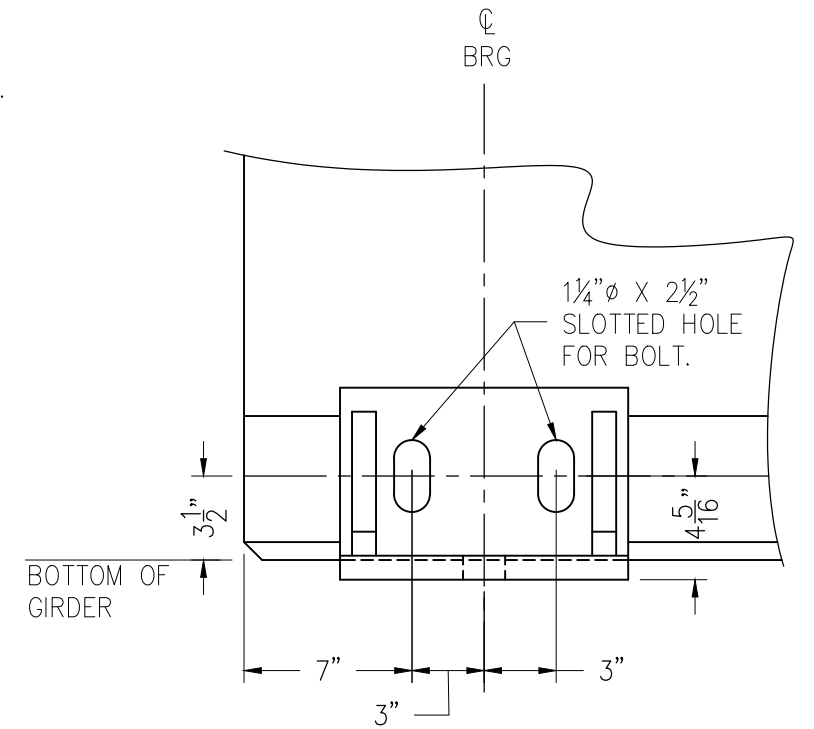

**PART ELEVATION**

SCALE 1 1/2" = 1'-0"

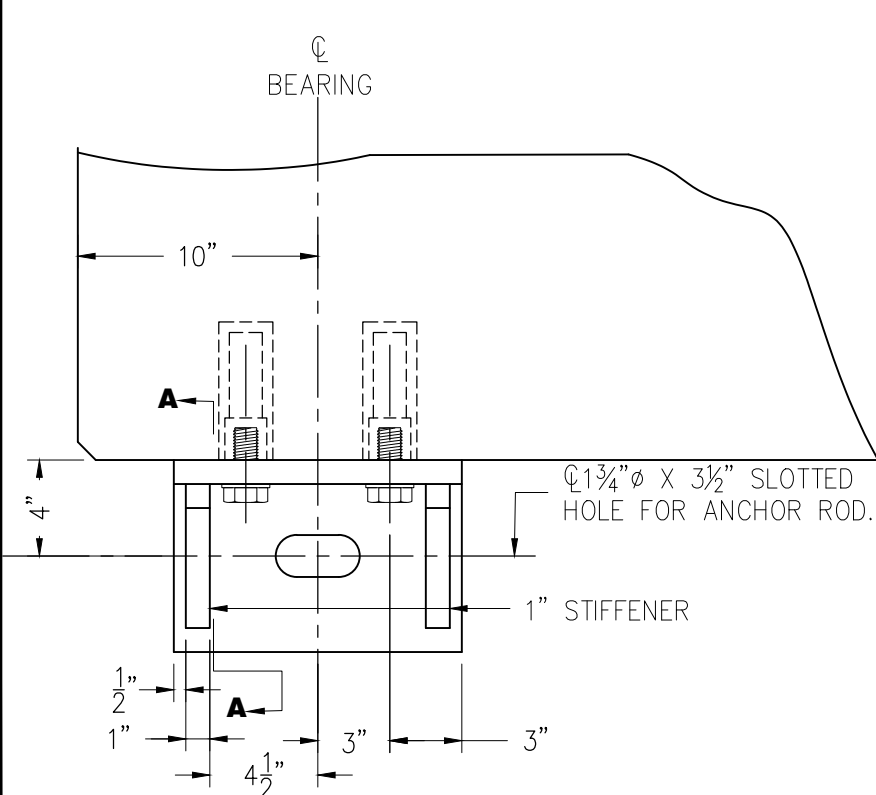

**PART PLAN AT GIRDER EXPANSION END**

SCALE 1 1/2" = 1'-0"

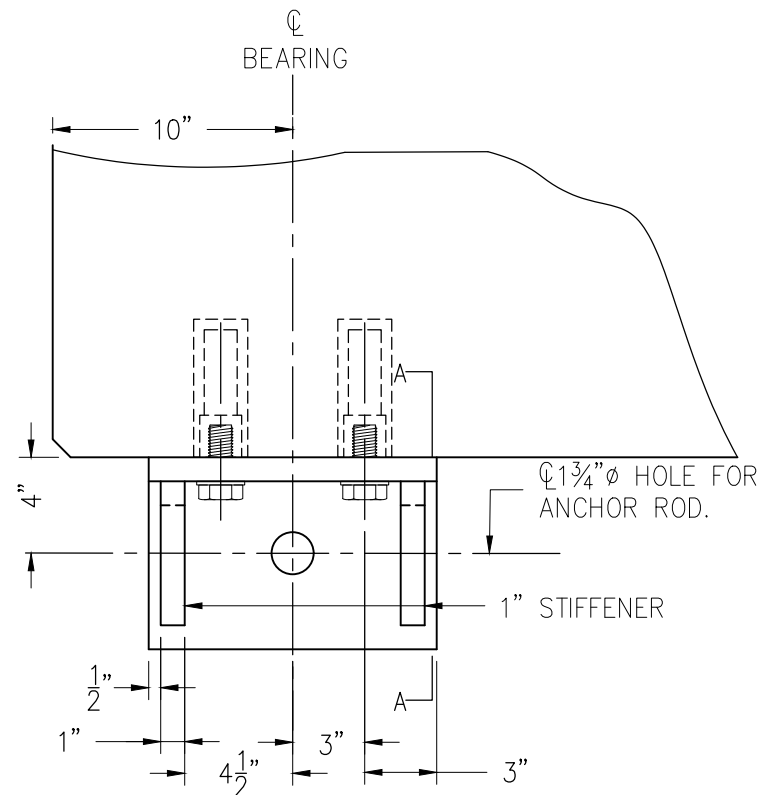

**PART PLAN AT GIRDER FIXED END**

SCALE 1 1/2" = 1'-0"

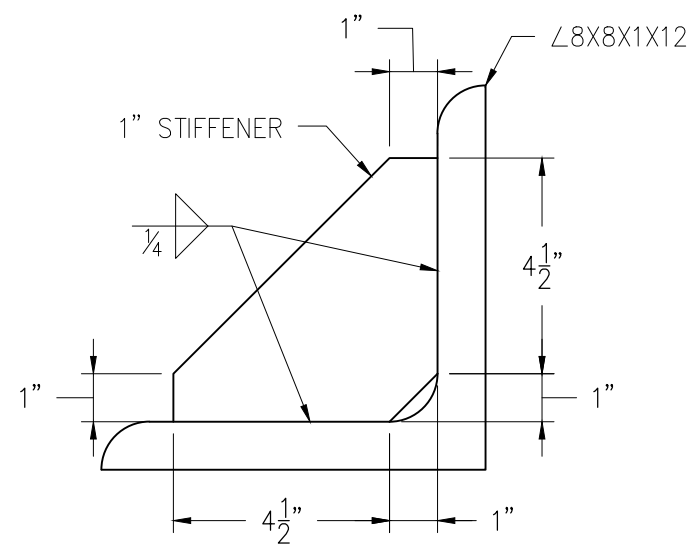

**SECTION A - A**

NO SCALE  
ESTIMATED WEIGHT = 62 LBS.

P.O. BOX 107500, ANCHORAGE, ALASKA 99510-7500		
<b>PROJECT :</b> <b>STANDARD 28 FOOT SPAN CONCRETE BALLAST DECK (CBD)</b>		
<b>TITLE:</b> <b>GIRDER TO CAP CONNECTION CROSS SECTION AND DETAILS</b>		
<b>DESIGNED BY:</b> ARRC <b>DRAWN BY:</b> ARRC <b>CHECKED BY:</b> CDR <b>APPROVED BY:</b> BAL	<b>SCALE :</b> AS NOTED <b>DATE :</b> FEB 2019	<b>A/E NO.:</b> <b>ACAD FILE:</b> <b>DWG NO.</b> <b>3 OF 15</b>

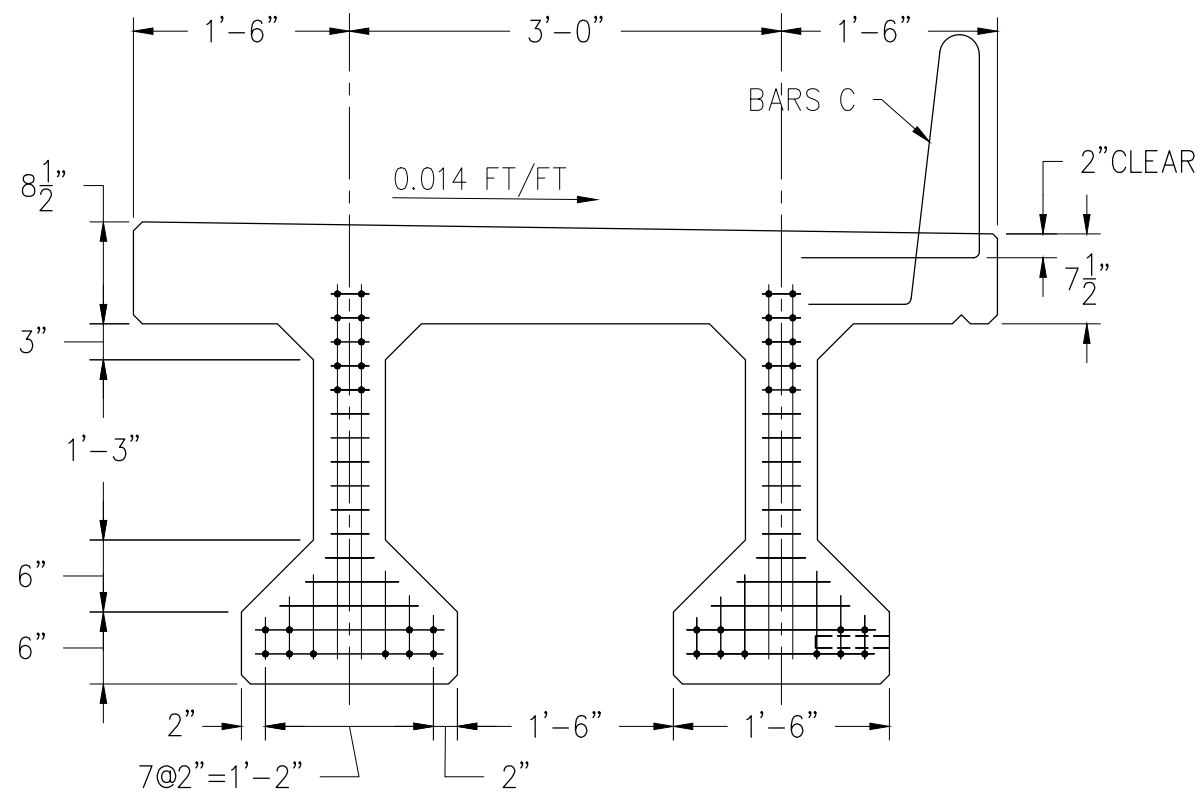

**STRAND PATTERNS AT BEARING (20 STRANDS)**

SCALE  $\frac{3}{4}$ " = 1'-0"

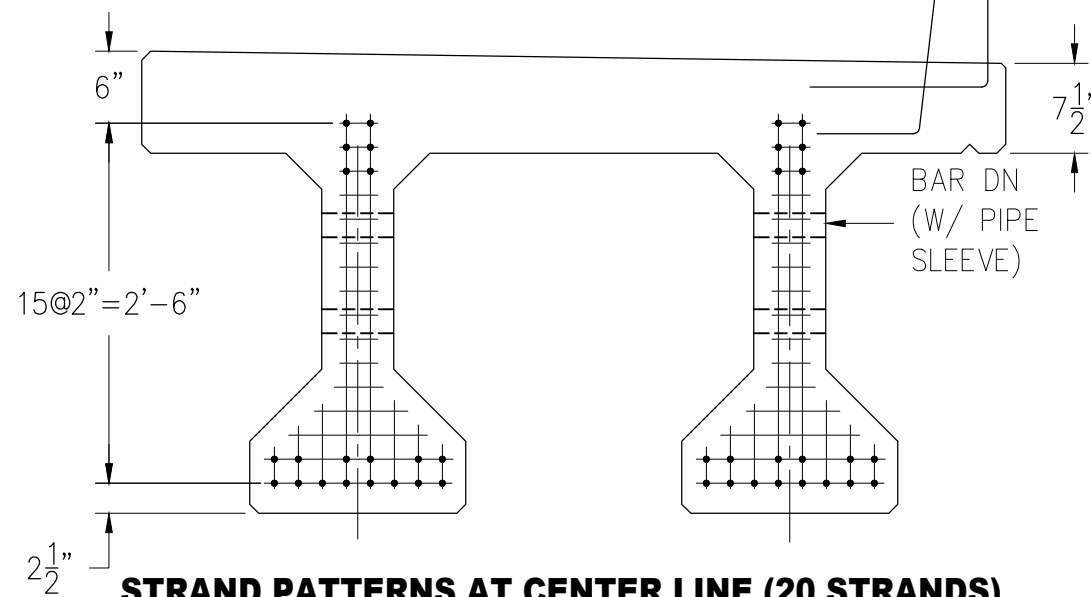

**STRAND PATTERNS AT CENTER LINE (20 STRANDS)**

SCALE  $\frac{3}{4}$ " = 1'-0"

ESTIMATED WEIGHT OF GIRDER = 17.1 TONS (8.4 CUBIC YARDS)

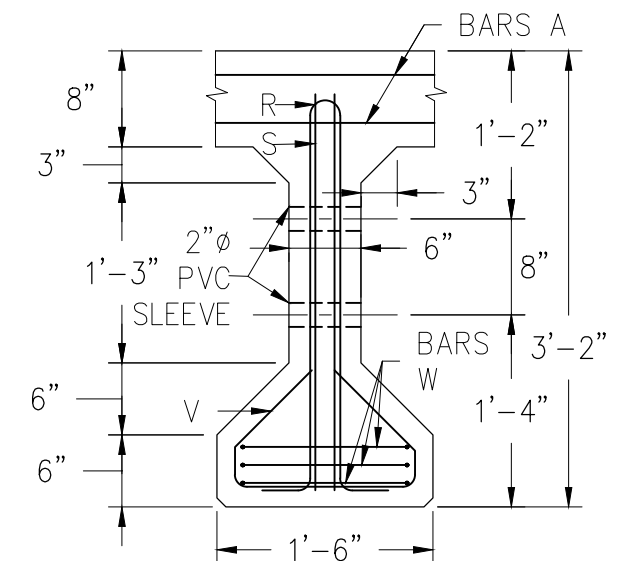

**GIRDER (AVG. HEIGHT)**

SCALE  $\frac{3}{4}$ " = 1'-0"

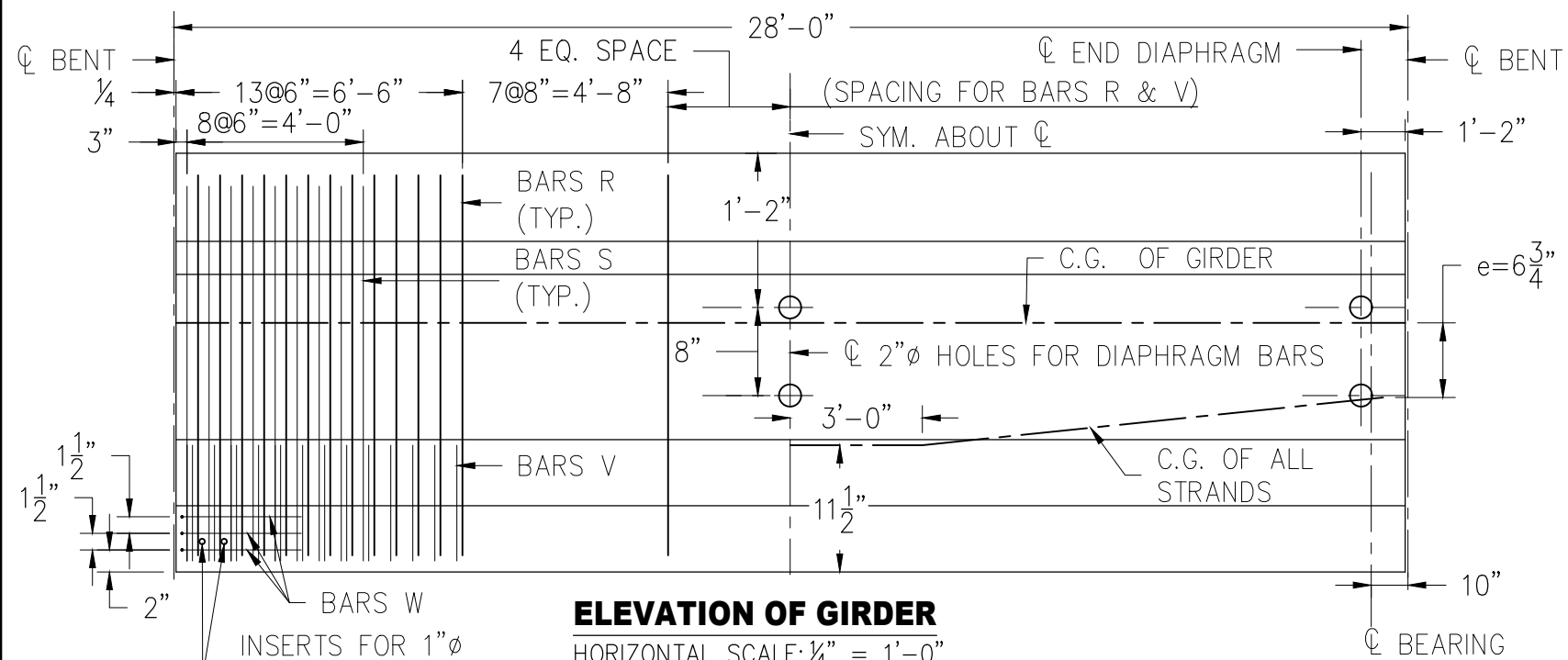

**ELEVATION OF GIRDER**

HORIZONTAL SCALE:  $\frac{1}{4}$ " = 1'-0"

VERTICAL SCALE:  $\frac{3}{4}$ " = 1'-0"

INSERTS FOR 1"Ø BOLTS, FOR DETAILS, SEE SHEET 3.

**NOTES:**

1. DECK REINFORCEMENT NOT SHOWN; SEE SHEETS 5 AND 6.
2. COMPRESSIVE STRENGTH OF THE CAST-IN-PLACE REINFORCED CONCRETE DIAPHRAGM SHALL EXCEED 4,500 PSI AT 28 DAYS.

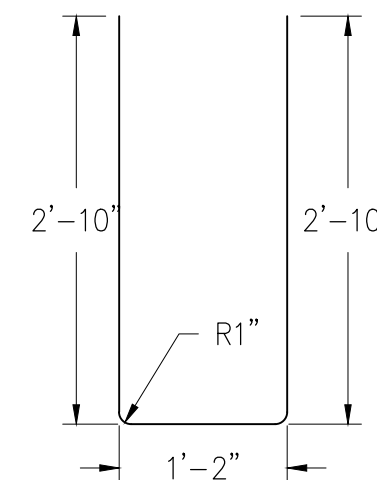

**BARS W - #5**

SCALE  $\frac{3}{4}$ " = 1'-0"

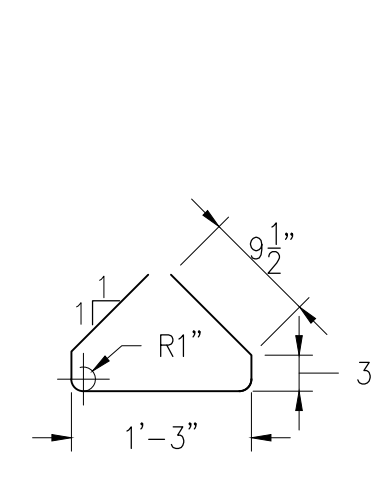

**BARS V - #3**

SCALE  $\frac{3}{4}$ " = 1'-0"

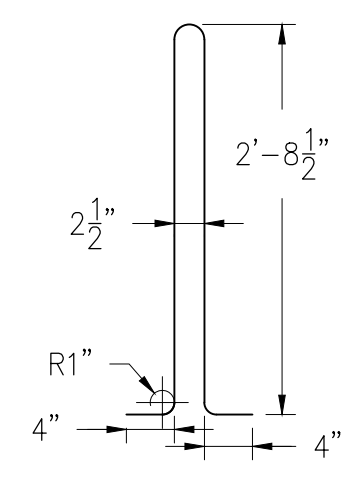

**BARS R - #5**

SCALE  $\frac{3}{4}$ " = 1'-0"

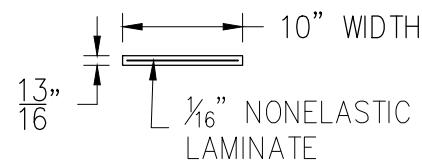

**LAMINATED BEARING**

NO SCALE

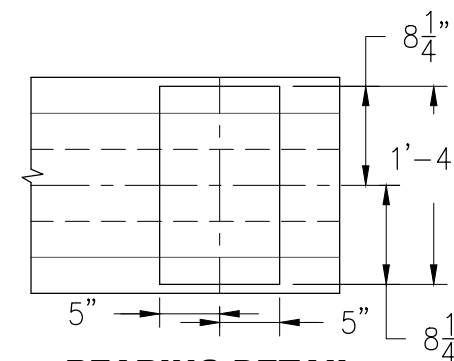

**BEARING DETAIL**

SCALE  $\frac{3}{4}$ " = 1'-0"

<b>ALASKA RAILROAD CORPORATION</b> ENGINEERING SERVICES P.O. BOX 107500, ANCHORAGE, ALASKA 99510-7500		
PROJECT :		
<b>STANDARD 28 FOOT SPAN          CONCRETE BALLAST DECK (CBD)</b>		
TITLE :		
<b>PRESTRESSED GIRDER          ELEVATION, SECTIONS, AND DETAILS</b>		
DESIGNED BY: FC	SCALE : AS NOTED	AFE NO.:
DRAWN BY: ARRC	DATE : FEB 2019	ACAD FILE:
CHECKED BY: CDR		DWG NO.
APPROVED BY: BAL		<b>4</b> OF <b>15</b>

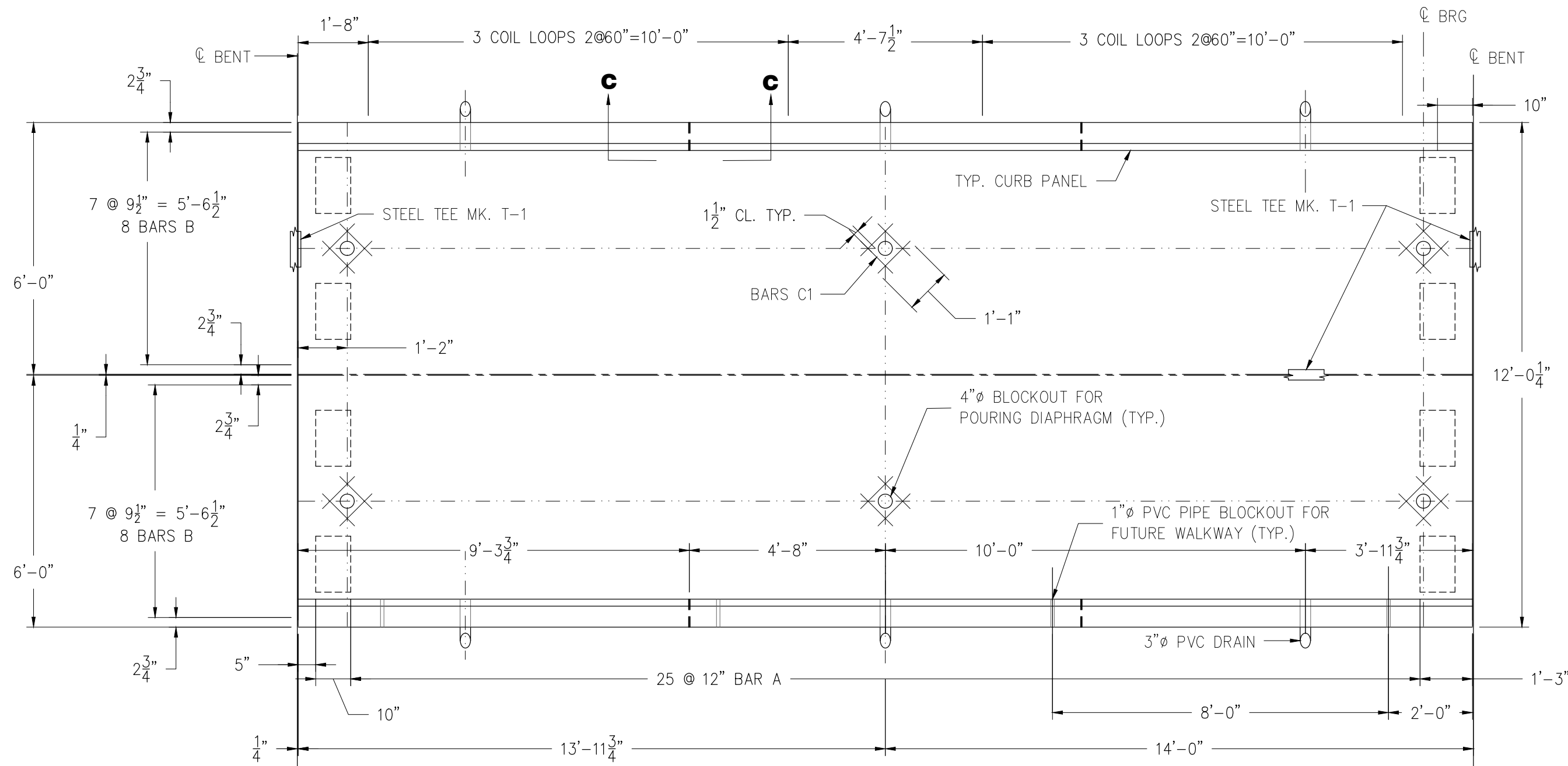

**DECK PLAN**  
SCALE  $\frac{3}{8}'' = 1'-0''$

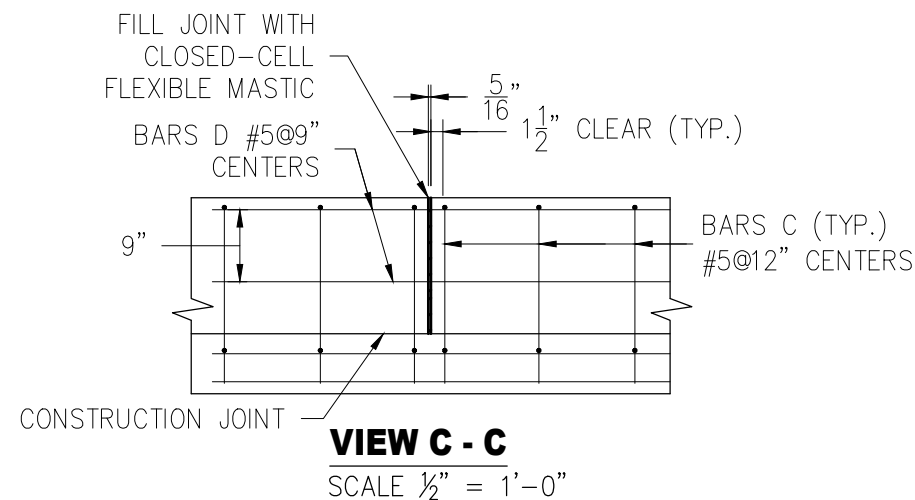

**VIEW C - C**  
SCALE  $\frac{1}{2}'' = 1'-0''$

NO  
1  
2  
3  
4

PROJECT : <b>STANDARD 28 FOOT SPAN CONCRETE BALLAST DECK (CBD)</b>		
TITLE : <b>TYPICAL PRECAST SUPERSTRUCTURE PLAN AND DETAIL</b>		
DESIGNED BY: ARRC	SCALE : AS NOTED	AFE NO.:
DRAWN BY: ARRC	DATE : FEB 2019	ACAD FILE:
CHECKED BY: CDR		DWG NO. <b>5</b> OF <b>15</b>
APPROVED BY: BAL		

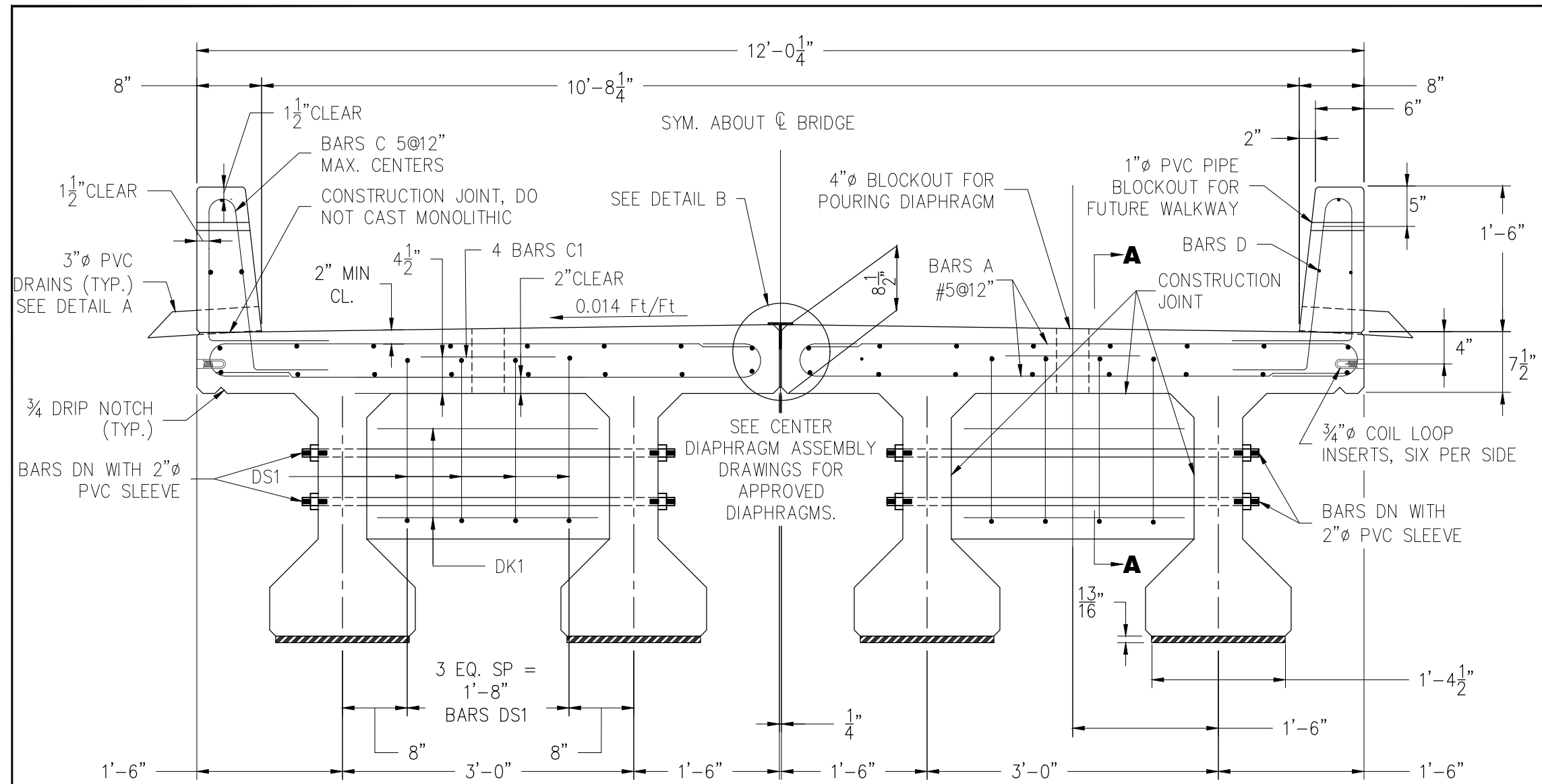

**TYPICAL SUPERSTRUCTURE SECTION**  
 SCALE: 3/4" = 1'-0" FOOTWALK BRACKET DETAIL NOT PROVIDED

REINFORCING SCHEDULE (1 SPAN)					
MARK	NO. REQ.	SIZE	LENGTH	SHAPE	WEIGHT
A	116	#5	6'-9"	BENT	817 lb
B	32	#5	27'-6 1/2"	ST	920 lb
C	60	#5	5'-9"	BENT	360 lb
C1	24	#4	1'-1"	ST	17 lb
D	18	#5	8'-11"	ST	168 lb
DS1	36	#4	4'-9"	BENT	114 lb
DK1	24	#5	2'-2"	ST	54 lb
R	188	BENT	#5	6'-3"	1224 lb
S	72	STR.	#5	2'-9"	208 lb
V	188	BENT	#3	3'-4"	236 lb
W	24	BENT	#5	6'-10"	172 lb
DN	12	1"φ	4'-3"	ST	162 lb

- NOTES:
1. COMPRESSIVE STRENGTH OF THE CAST-IN-PLACE REINFORCED CONCRETE CURB AND DIAPHRAGM SHALL EXCEED 4,500 PSI AT 28 DAYS.
  2. PLACE SQUARE WASHER PLATES UNDER NUTS FOR BARS DN. ASTM A36 HOT DIP GALVANIZED WASHER 3/8"X4"X4" WITH 1/8"φ HOLE AT CENTER.
  3. UTILITY SUPPORTS TYPICAL OF BOTH SIDES.
  4. ALASKA RAILROAD STOCK NO. 312969 (1/2 SPAN)

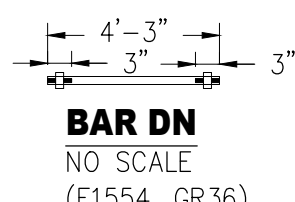
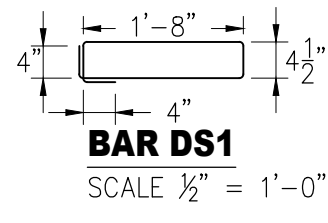
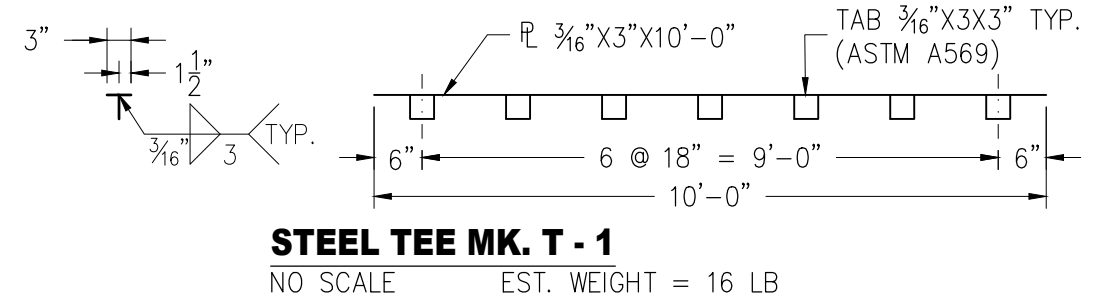
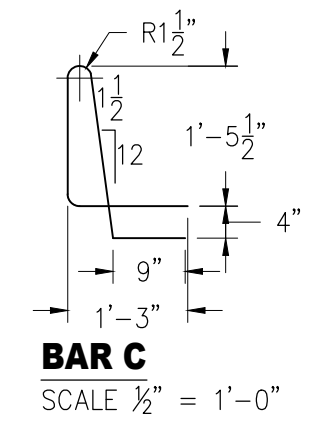
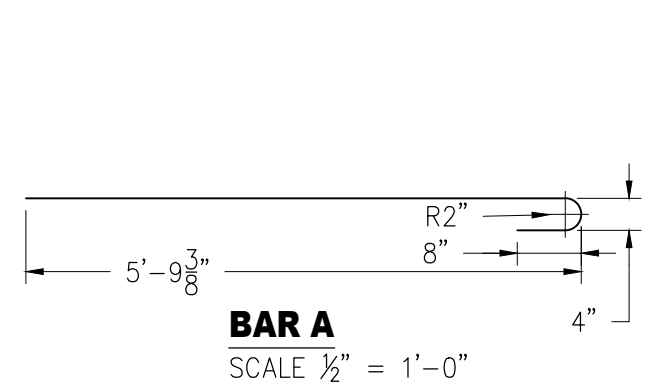
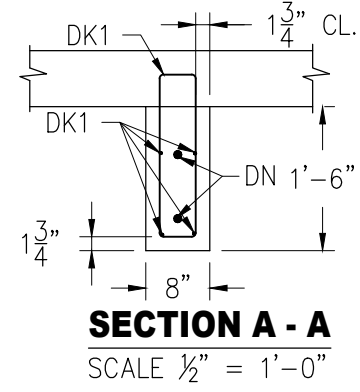
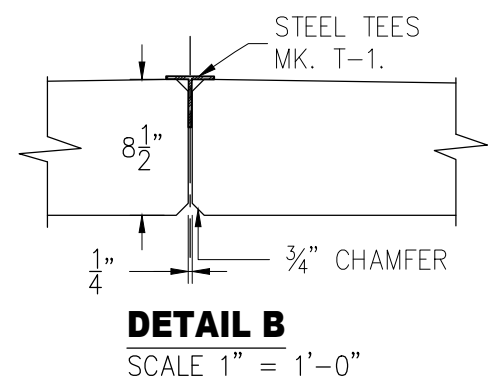
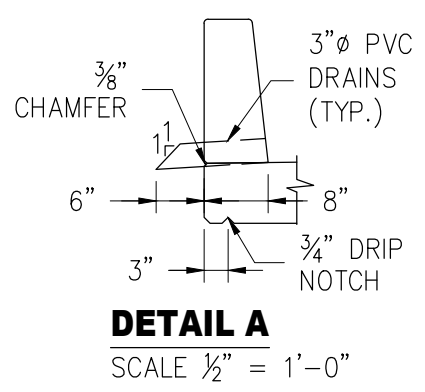

**ALASKA RAILROAD CORPORATION**  
 ENGINEERING SERVICES  
 P.O. BOX 107500, ANCHORAGE, ALASKA 99510-7500

PROJECT : **STANDARD 28 FOOT SPAN CONCRETE BALLAST DECK (CBD)**

TITLE: **TYPICAL PRECAST SUPERSTRUCTURE SECTION AND DETAILS**

DESIGNED BY: ARRC	SCALE : AS NOTED	AFE NO.:
DRAWN BY: ARRC	DATE : FEB 2019	ACAD FILE:
CHECKED BY: CDR		DWG NO. <b>6</b> OF <b>15</b>
APPROVED BY: BAL		

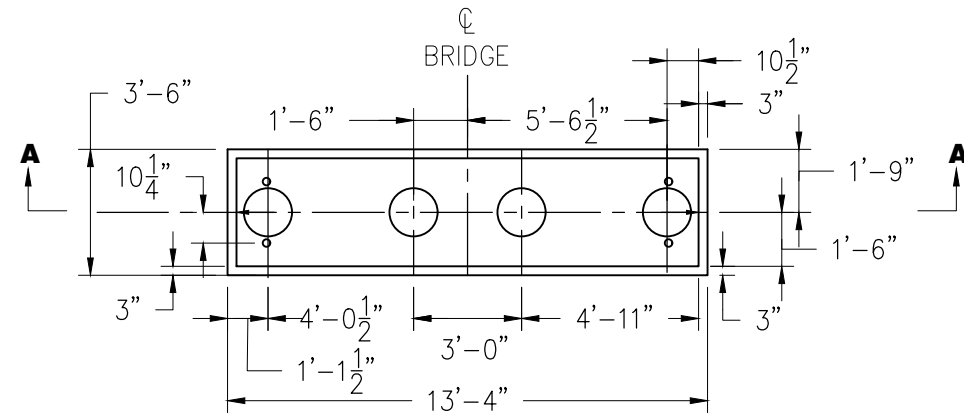

**ONE ROW BENT PLAN**  
SCALE  $\frac{3}{16}$ " = 1'-0"

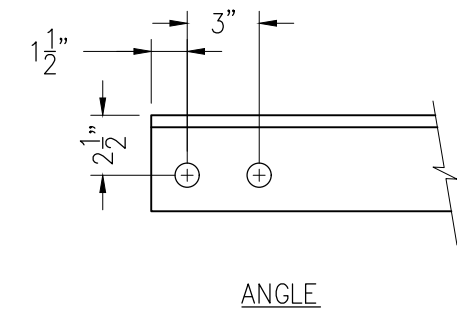
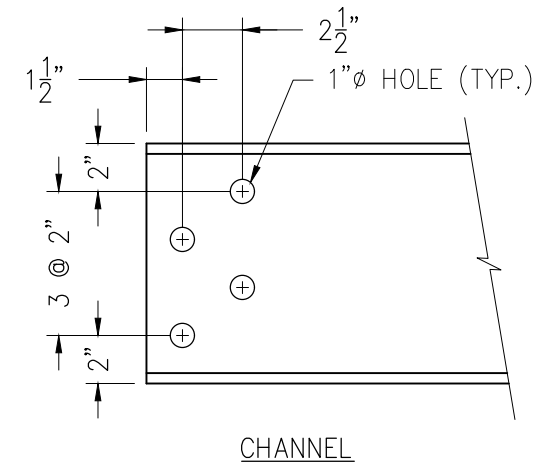

**BRACING DETAIL A**  
SCALE  $\frac{1}{2}$ " = 1'-0"

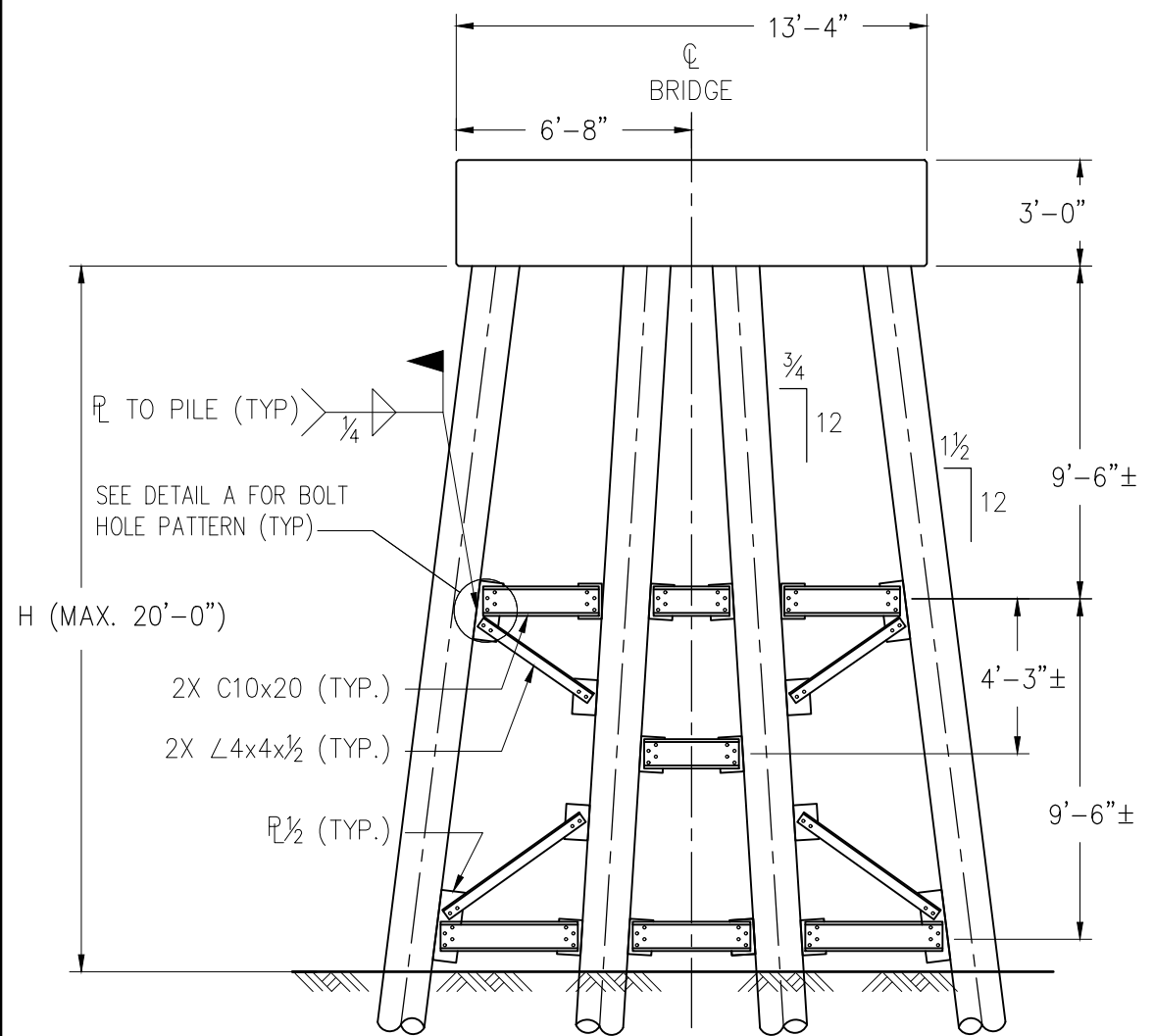

**ONE ROW BENT BRACING**  
SCALE  $\frac{3}{16}$ " = 1'-0"

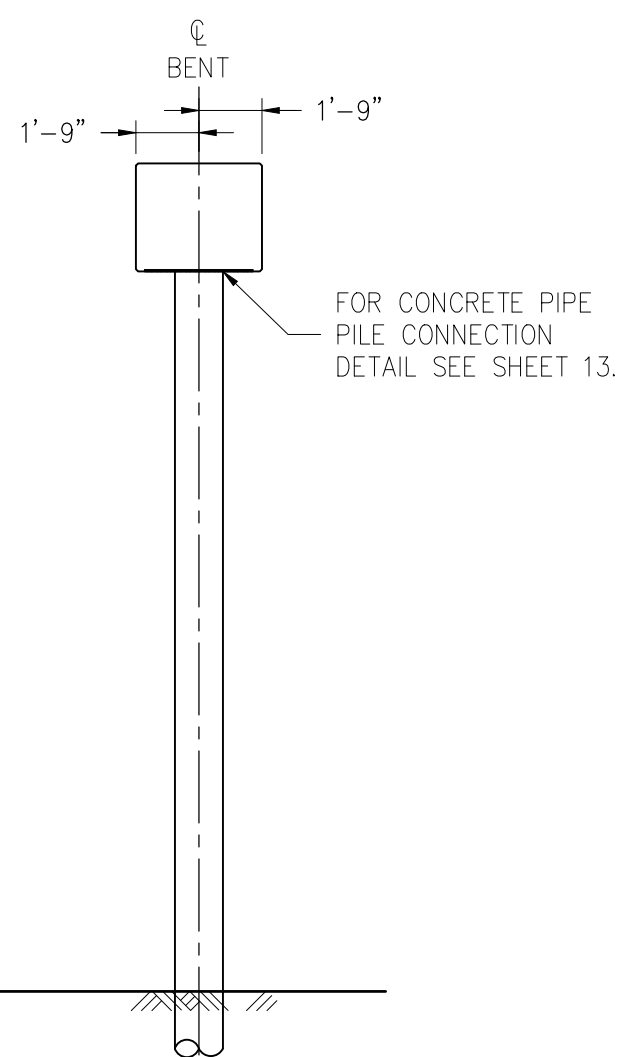

**ONE ROW BENT SIDE ELEVATION**  
SCALE  $\frac{3}{16}$ " = 1'-0"

NOTES:

1. PILE DESIGN LOAD SHALL BE 100 TONS PER PILE.
2. ESTIMATED 16"Ø PILE WEIGHT = 83 LB/FT.
3. FOR MISCELLANEOUS PIPE PILE DETAILS, SEE SHEET 13.
4. WELD SHALL BE IN ACCORDANCE WITH CHAPTER 15 OF THE CURRENT AREMA MANUAL AND AWS D1.5-15.

<b>ALASKA RAILROAD CORPORATION</b> ENGINEERING SERVICES P.O. BOX 107500, ANCHORAGE, ALASKA 99510-7500		
PROJECT :		
<b>STANDARD 28 FOOT CONCRETE BALLAST DECK (CBD)</b>		
TITLE:		
<b>FOUR PILE, SINGLE ROW BENT PLAN, ELEVATION AND DETAILS</b>		
DESIGNED BY: ARRC	SCALE : AS NOTED	AFE NO.:
DRAWN BY: ARRC	DATE : FEB 2019	ACAD FILE:
CHECKED BY: CDR		DWG NO. <b>7</b> OF <b>15</b>
APPROVED BY: BAL		

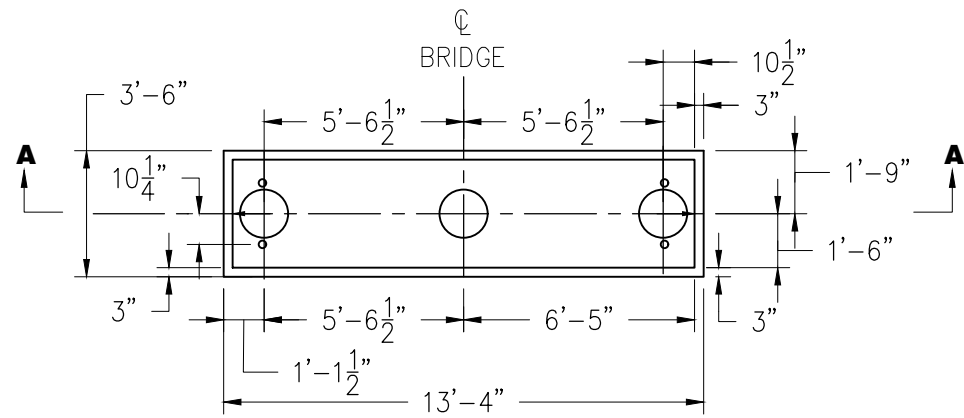

**ONE ROW BENT PLAN**

SCALE  $\frac{3}{16}$ " = 1'-0"

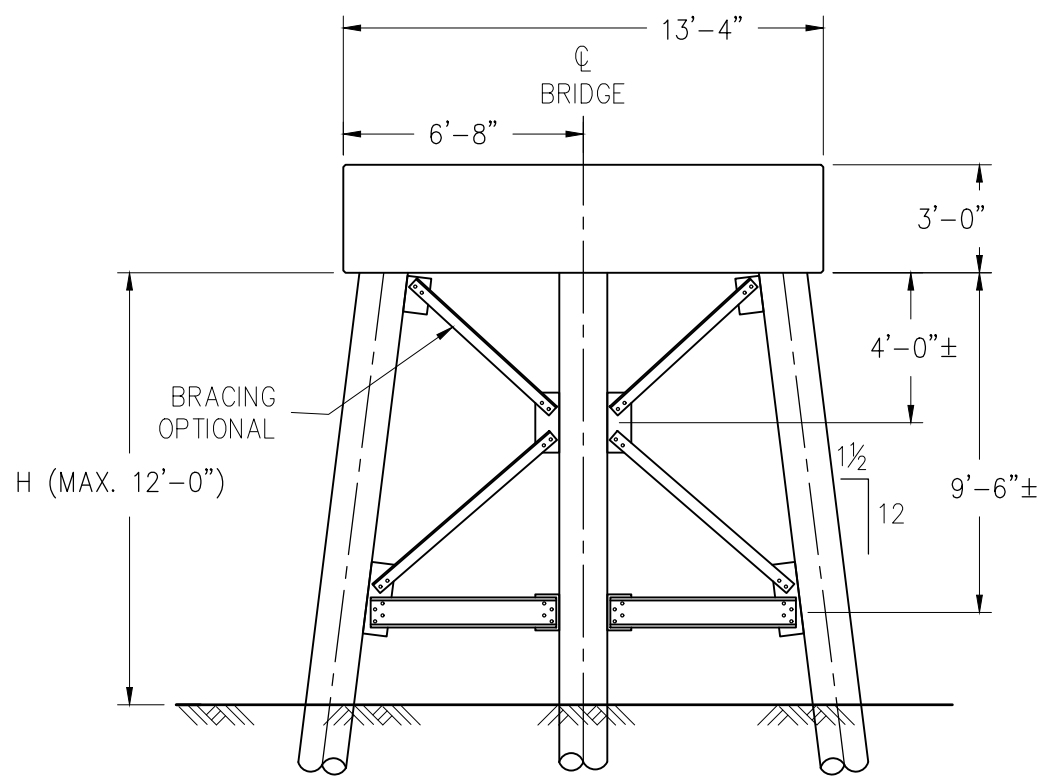

**ONE ROW BENT BRACING**

SCALE  $\frac{3}{16}$ " = 1'-0"

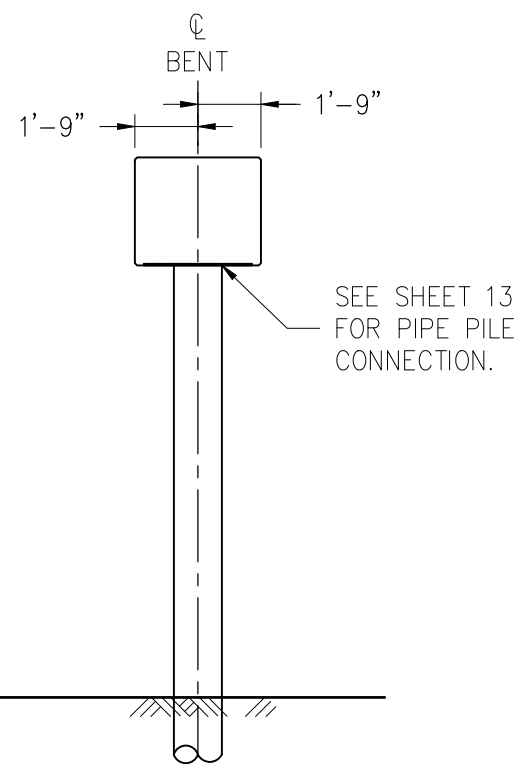

**ONE ROW BENT SIDE ELEVATION**

SCALE  $\frac{3}{16}$ " = 1'-0"

NOTES:

1. PILE DESIGN LOAD SHALL BE 100 TONS PER PILE.
2. ESTIMATED 16"Ø PILE WEIGHT = 83 LB/FT.
3. FOR MISCELLANEOUS PIPE PILE DETAILS, SEE SHEET 13.
4. FOR TYPICAL PILE BRACING DETAILS SEE SHEET 10.
5. WELD SHALL BE IN ACCORDANCE WITH CHAPTER 15 OF THE CURRENT AREMA MANUAL AND AWS D1.5-15.

<b>ALASKA RAILROAD CORPORATION</b> ENGINEERING SERVICES P.O. BOX 107500, ANCHORAGE, ALASKA 99510-7500		
PROJECT :		
<b>STANDARD 28 FOOT CONCRETE BALLAST DECK (CBD)</b>		
TITLE:		
<b>THREE PILE, SINGLE ROW BENT PLAN, ELEVATION AND DETAILS</b>		
DESIGNED BY: <u>ARRC</u>	SCALE : AS NOTED	AFE NO.:
DRAWN BY: <u>ARRC</u>	DATE : FEB 2019	ACAD FILE:
CHECKED BY: <u>CDR</u>		DWG NO.:
APPROVED BY: <u>BAL</u>		<b>8</b> OF <b>15</b>

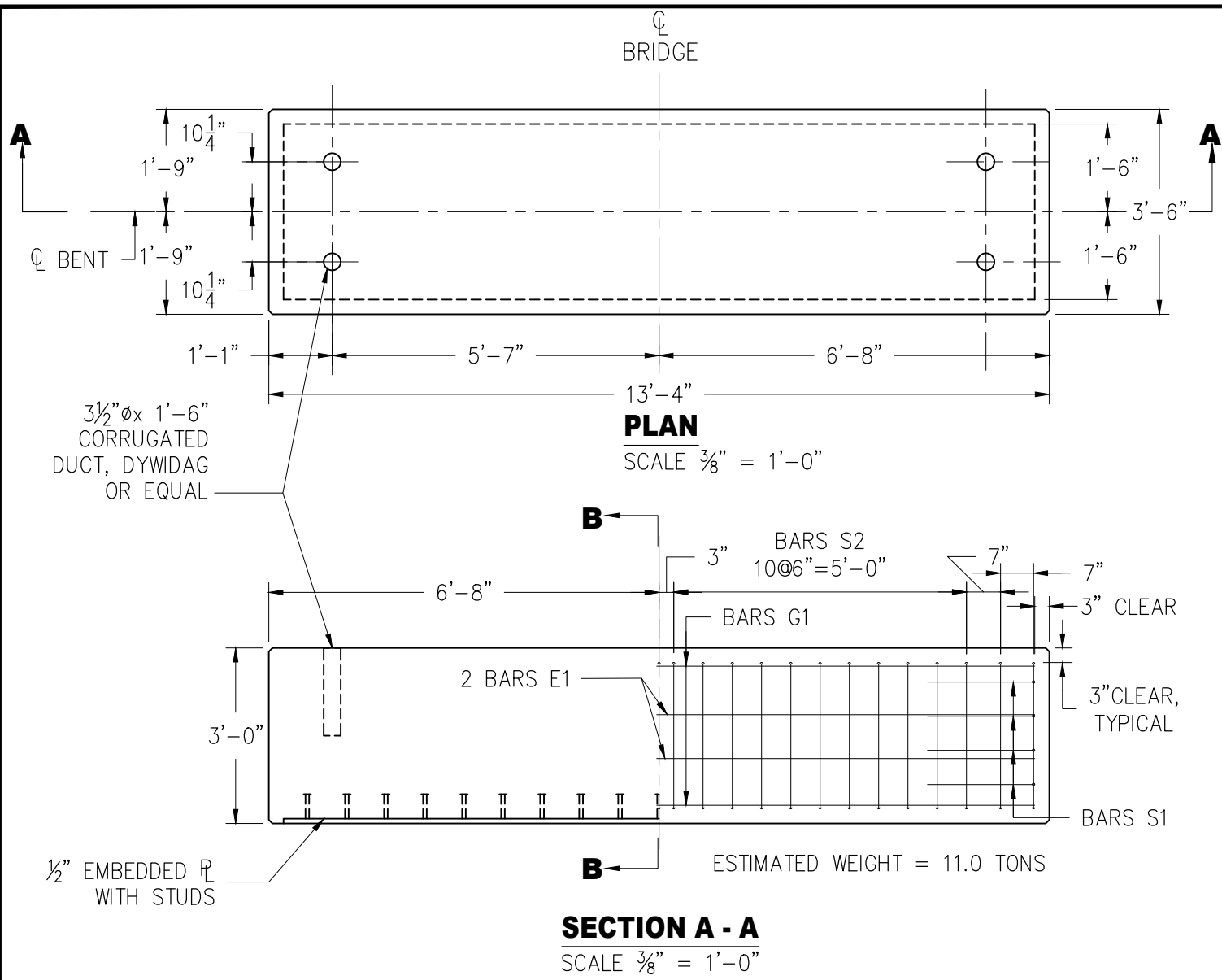

REINFORCING SCHEDULE (1 CAP)					
MARK	REQ. NO	TYPE	SIZE	LENGTH	WEIGHT (LB)
E1	4	STR	#6	12'-10"	78
G1	8	STR	#8	12'-10"	274
S1	8	BENT	#5	5'-10"	49
S2	52	BENT	#5	9'-9"	529

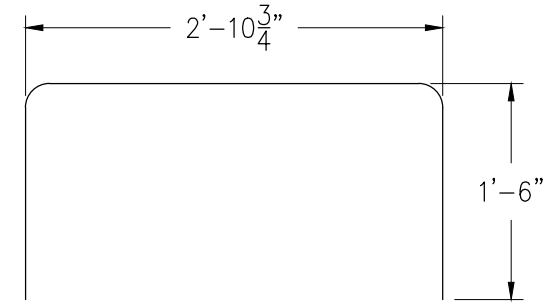
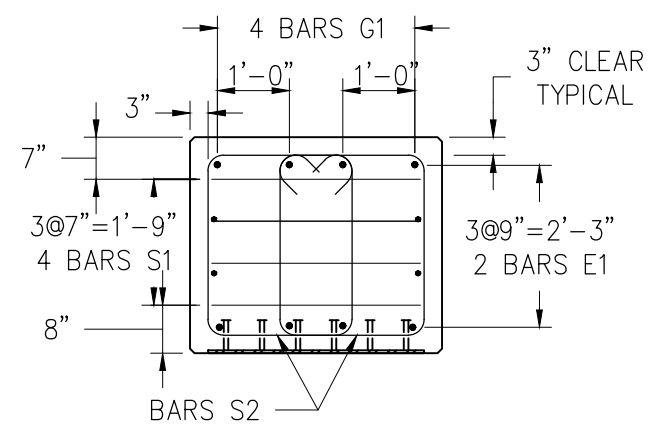

**BARS S1**  
SCALE 3/4" = 1'-0"

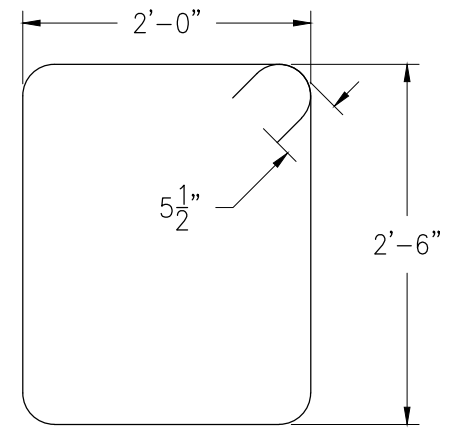

**BARS S2**  
SCALE 3/4" = 1'-0"

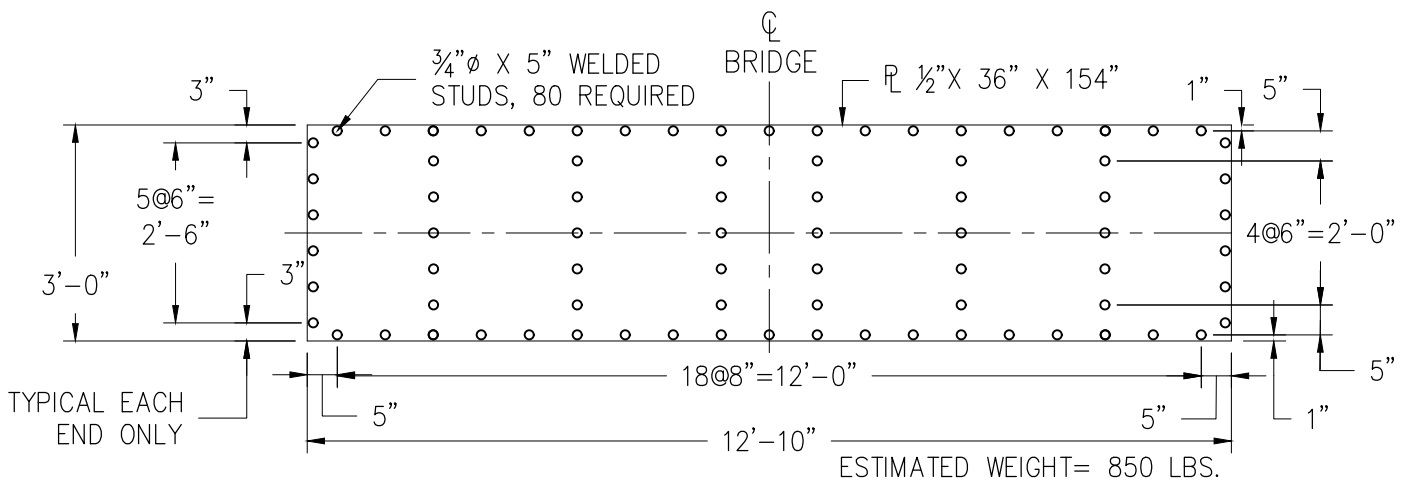
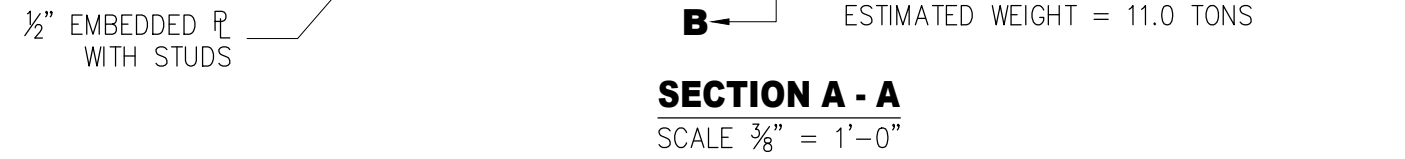

**EMBEDDED PLATE DETAIL**  
SCALE 3/8" = 1'-0"

- NOTES:
1. PROVIDE 3/4 INCH CHAMFER FOR ALL CONCRETE CORNERS.
  2. THE CONCRETE BENT CAP MUST BE CONSTRUCTED SO THE TOP AND BOTTOM SURFACES ARE PARALLEL. THE TOP AND BOTTOM SURFACES MUST BE FINISHED FLAT WITH NO VARIANCES TO EXCEED 1/8 INCH UNDER A 10 FOOT LONG STRAIGHT EDGE. ALL VARIATIONS TO THIS REQUIREMENT MUST BE CORRECTED TO THE SATISFACTION OF ALASKA RAILROAD PRIOR TO ACCEPTANCE.
  3. EXTRA ATTENTION SHOULD BE DIRECTED TO PLACEMENT OF THE DYWIDAGS SO THAT THEY ARE CONSISTENT WITH THE DRAWINGS.
  4. ALASKA RAILROAD STOCK NO. 312971

<b>ALASKA RAILROAD CORPORATION</b> ENGINEERING SERVICES P.O. BOX 107500, ANCHORAGE, ALASKA 99510-7500		
PROJECT :		
<b>STANDARD 28 FOOT CONCRETE BALLAST DECK (CBD)</b>		
TITLE:		
<b>SINGLE ROW PILE CAP PLAN AND DETAILS</b>		
DESIGNED BY: ARRC	SCALE : AS NOTED	AFE NO.:
DRAWN BY: ARRC	DATE : FEB 2019	ACAD FILE:
CHECKED BY: CDR		DWG NO. <b>9</b> OF <b>15</b>
APPROVED BY: BAL		



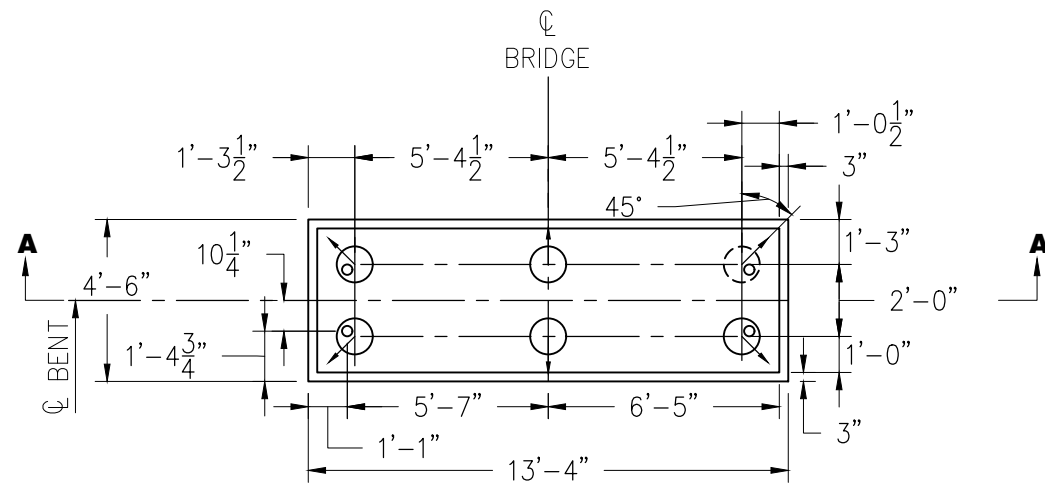

**TWO ROW BENT PLAN**

SCALE  $\frac{3}{16}$ " = 1'-0"

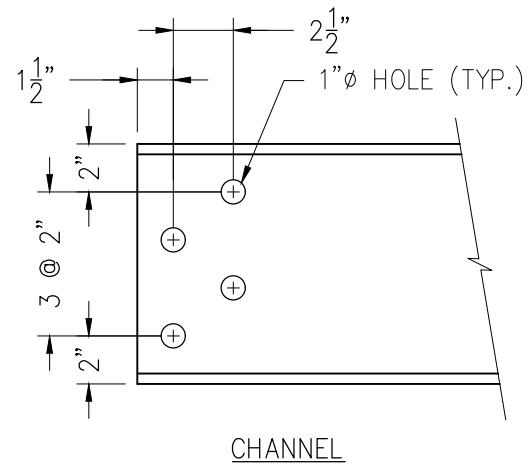

**BRACING DETAIL A**

SCALE  $1\frac{1}{2}$ " = 1'-0"

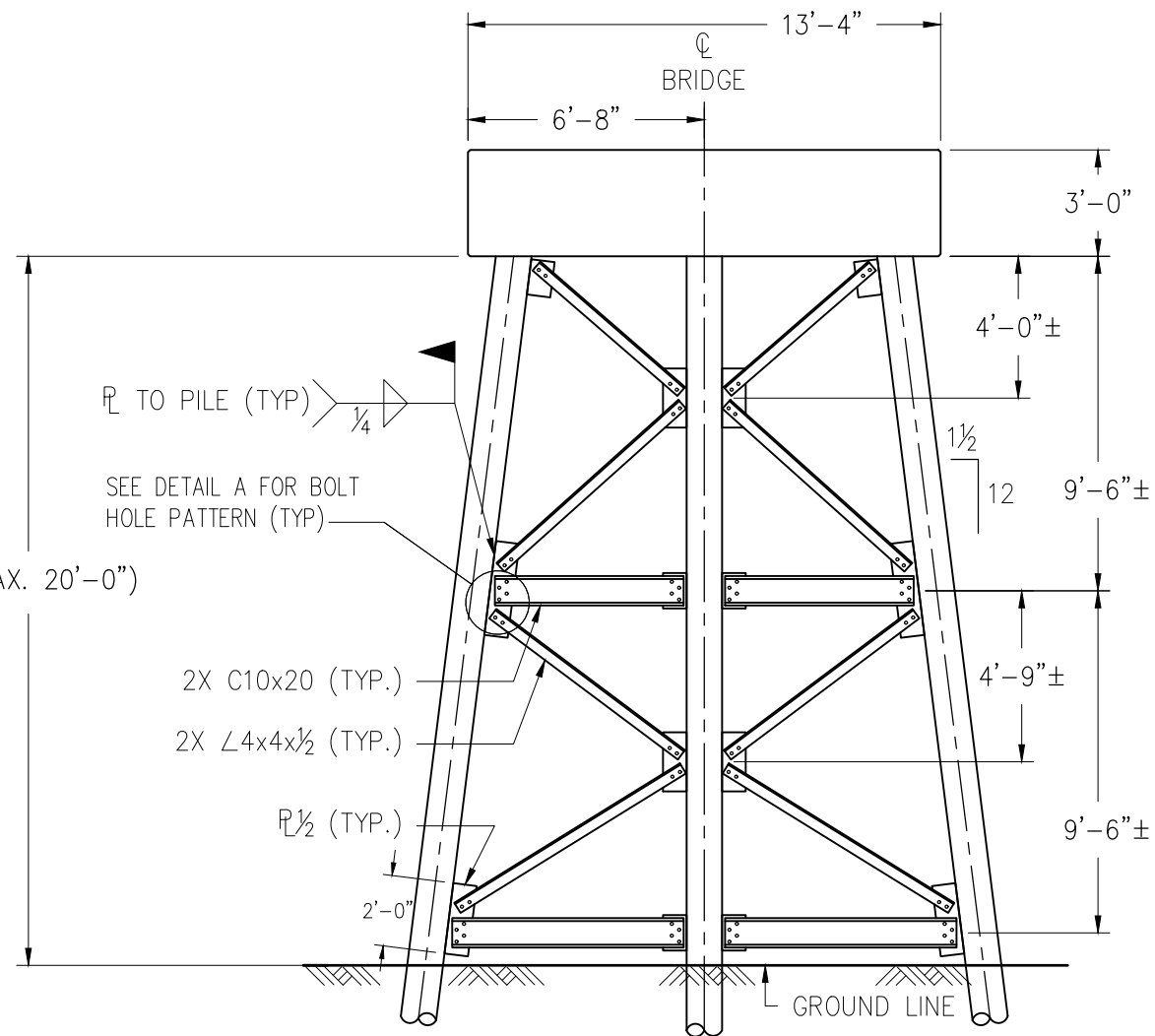
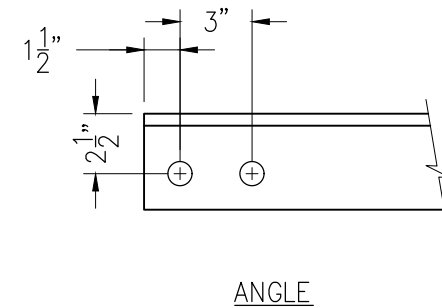

**TWO ROW BENT BRACING**

SCALE  $\frac{3}{16}$ " = 1'-0"

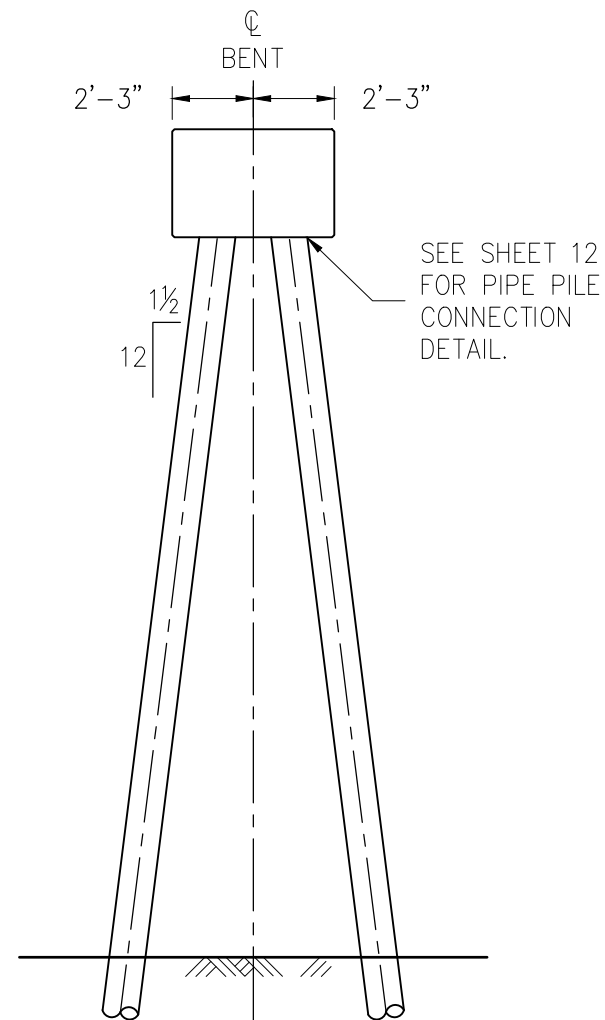

**TWO ROW BENT SIDE ELEVATION**

SCALE  $\frac{3}{16}$ " = 1'-0"

**NOTES:**

1. PILE DESIGN LOAD SHALL BE 100 TONS PER PILE.
2. ESTIMATED 12"Ø PILE WEIGHT = 62 LB/FT.
3. FOR MISCELLANEOUS PIPE PILE DETAILS, SEE SHEET 12.
4. WELD SHALL BE IN ACCORDANCE WITH CHAPTER 15 OF THE CURRENT AREMA MANUAL AND AWS D1.5-15.

<b>ALASKA RAILROAD CORPORATION</b> ENGINEERING SERVICES P.O. BOX 107500, ANCHORAGE, ALASKA 99510-7500		
PROJECT :		
<b>STANDARD 28 FOOT CONCRETE BALLAST DECK (CBD)</b>		
TITLE:		
<b>TWO ROW BENT PLAN, ELEVATION AND DETAILS</b>		
DESIGNED BY: ARRC	SCALE : AS NOTED	AFE NO.:
DRAWN BY: ARRC	DATE : FEB 2019	ACAD FILE:
CHECKED BY: CDR		DWG NO. <b>10</b> OF <b>15</b>
APPROVED BY: BAL		

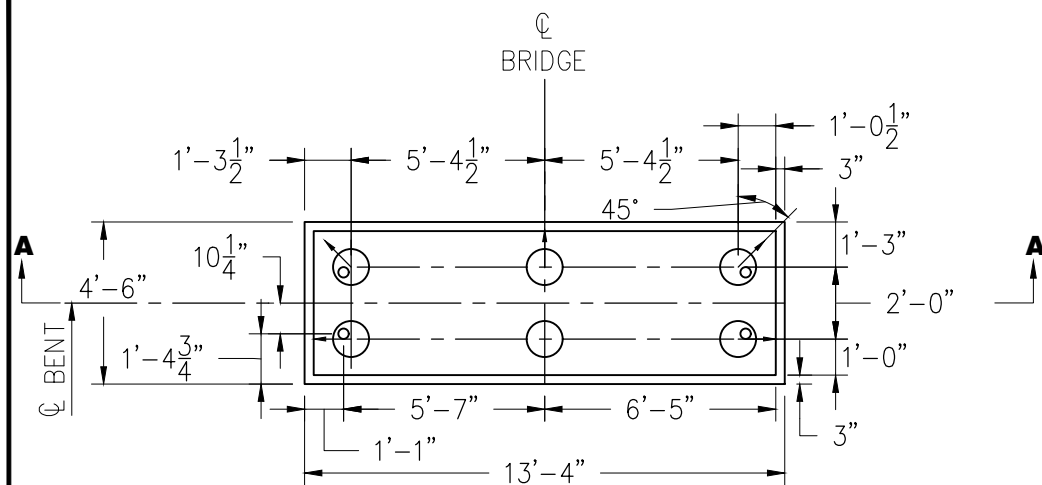

**TWO ROW ABUTMENT PLAN**

SCALE  $\frac{3}{16}$ " = 1'-0"

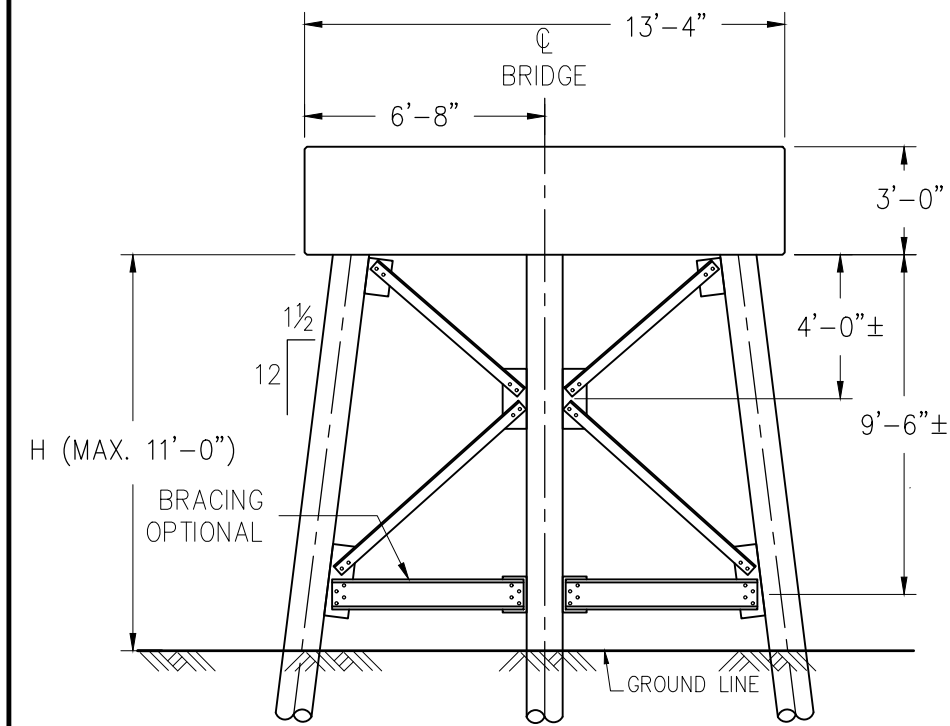

**TWO ROW ABUTMENT BRACING PLAN**

SCALE  $\frac{3}{16}$ " = 1'-0"

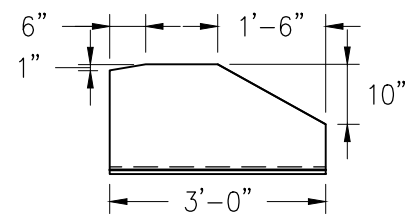

**BULKHEAD CLOSURE PLATE**

SCALE  $\frac{3}{8}$ " = 1'-0"

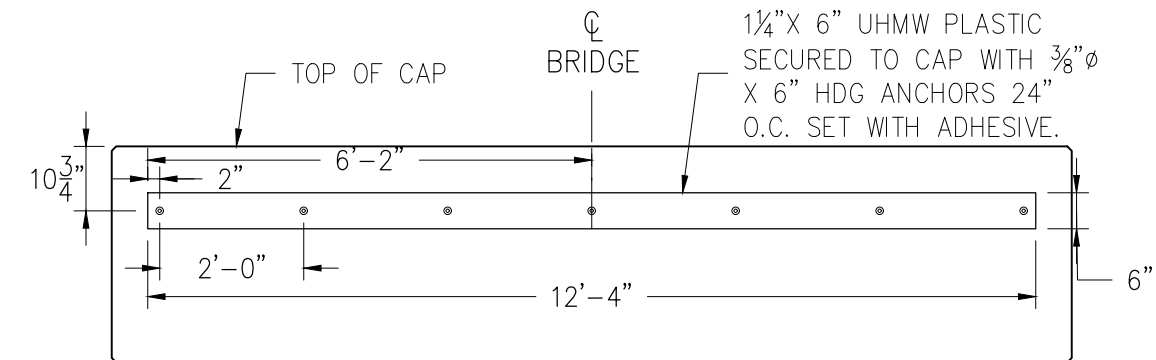
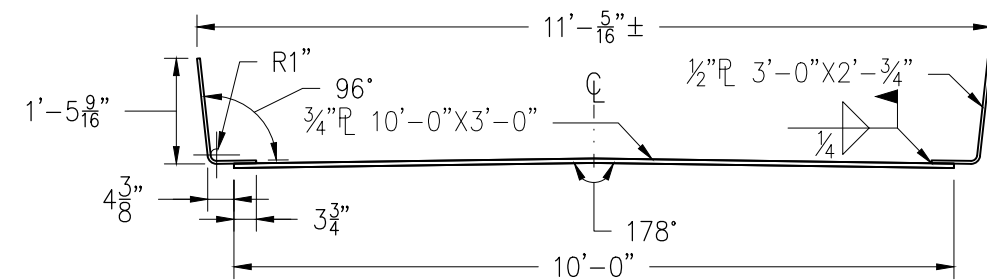

**BULKHEAD CAP BEARING PAD**

SCALE  $\frac{3}{8}$ " = 1'-0"

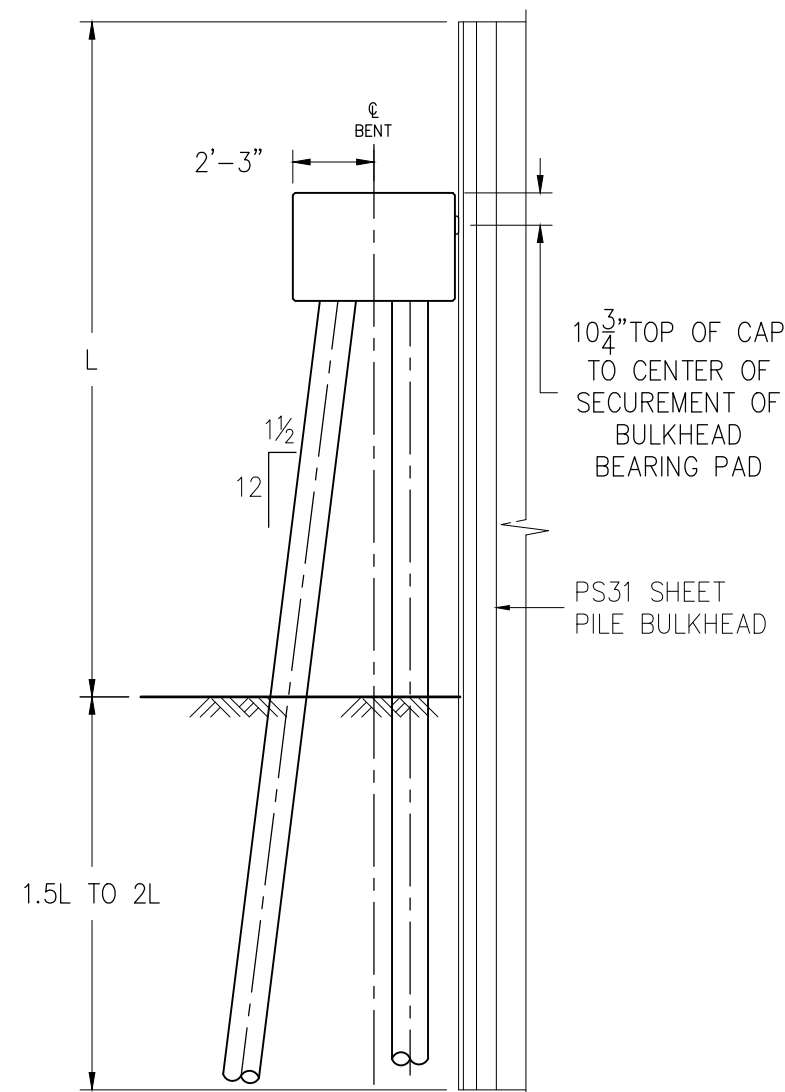

**TWO ROW ABUTMENT SIDE ELEVATION**

SCALE  $\frac{3}{16}$ " = 1'-0"

**NOTES:**

1. PILE DESIGN LOAD SHALL BE 100 TONS PER PILE.
2. ESTIMATED 12"Ø PILE WEIGHT = 65.4 LB/FT.
3. FOR MISCELLANEOUS PIPE PILE DETAILS, SEE SHEET 13.
4. FOR TYPICAL PILE BRACING DETAILS SEE SHEET 10.
5. WELD SHALL BE IN ACCORDANCE WITH CHAPTER 15 OF THE CURRENT AREMA MANUAL AND AWS D1.5-15.
6. INSTALL BULKHEAD CLOSURE PLATE TO SPAN OPENING BETWEEN BRIDGE AND BULKHEAD USING FIELD BORED HOLES TO PLACE BOLT KEEPERS, NOT SHOWN.

<b>ALASKA RAILROAD CORPORATION</b> ENGINEERING SERVICES P.O. BOX 107500, ANCHORAGE, ALASKA 99510-7500		
PROJECT :		
<b>STANDARD 28 FOOT CONCRETE BALLAST DECK (CBD)</b>		
TITLE:		
<b>TWO ROW BENT ABUTMENT PLAN, ELEVATION AND DETAILS</b>		
DESIGNED BY: ARRC	SCALE : AS NOTED	AFE NO.:
DRAWN BY: ARRC	DATE : FEB 2019	ACAD FILE:
CHECKED BY: CDR		DWG NO.:
APPROVED BY: BAL		<b>11</b> OF <b>15</b>

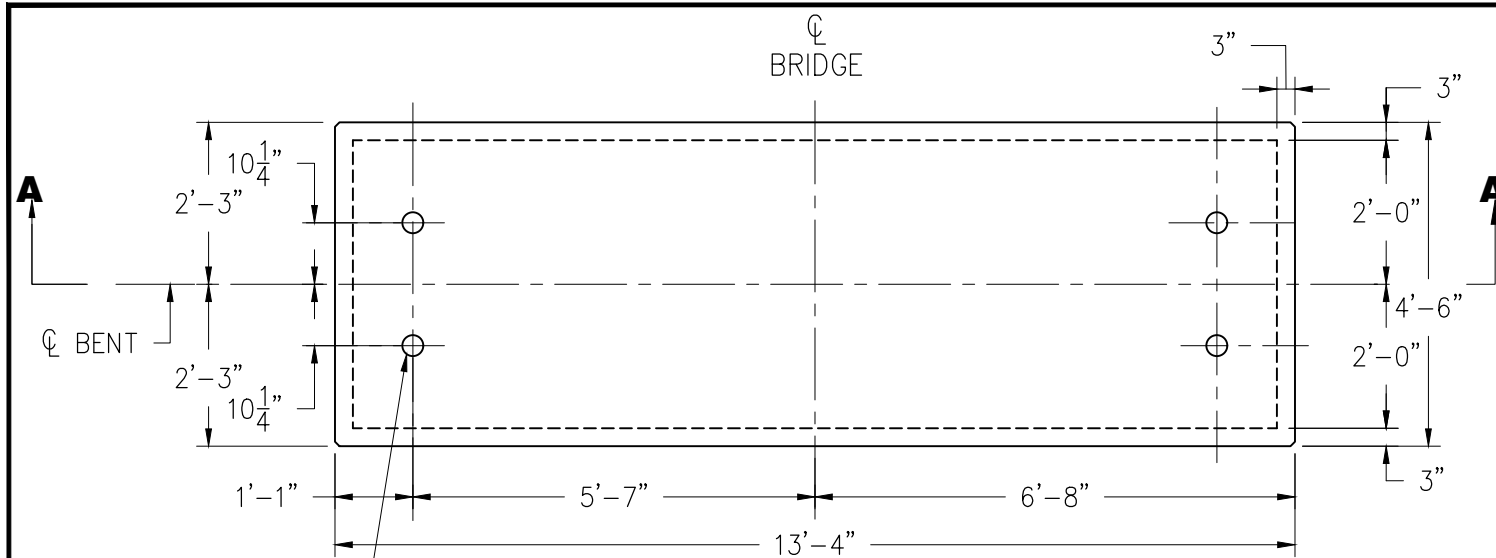

**PLAN**  
SCALE 3/8" = 1'-0"

REINFORCING SCHEDULE (1 CAP)					
MARK	REQ. NO	TYPE	SIZE	LENGTH	WEIGHT (LB)
E1	4	STR	#6	12'-10"	78
G1	12	STR	#8	12'-10"	412
S1	8	BENT	#5	6'-10"	57
S2	52	BENT	#5	10'-8"	579

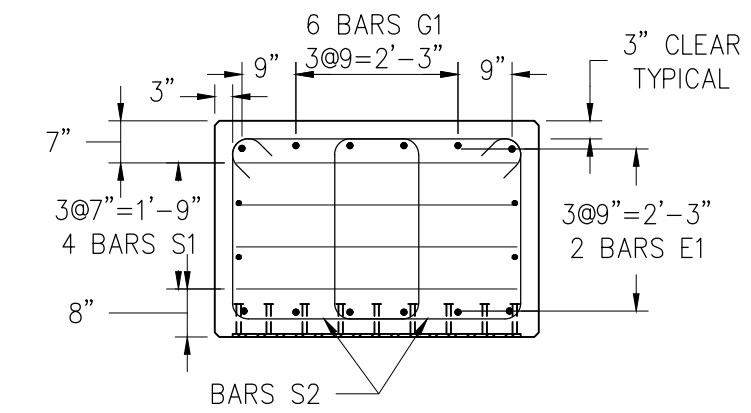

**SECTION B - B**  
SCALE 3/8" = 1'-0"

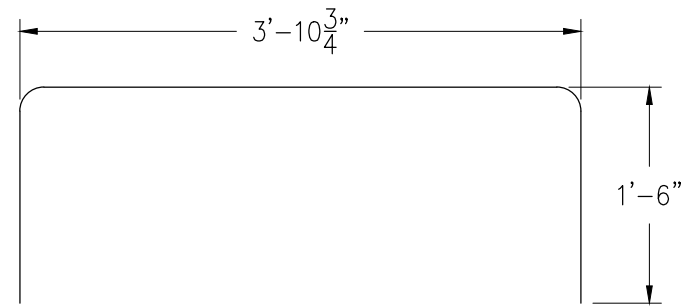

**BARS S1**  
SCALE 3/4" = 1'-0"

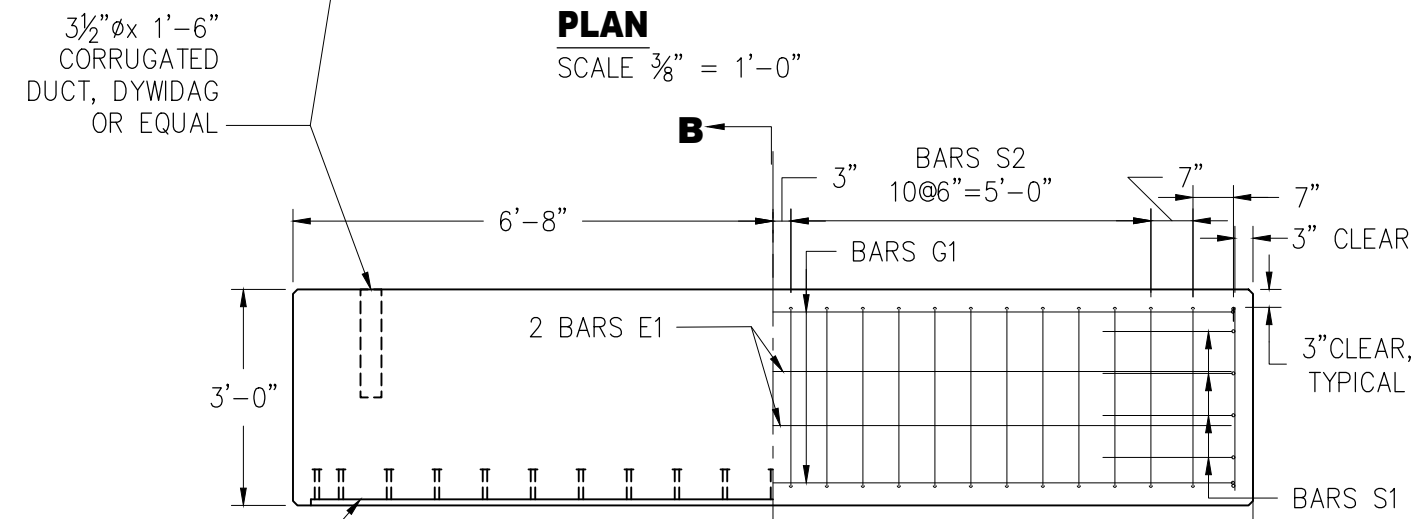

**SECTION A - A**  
SCALE 3/8" = 1'-0"

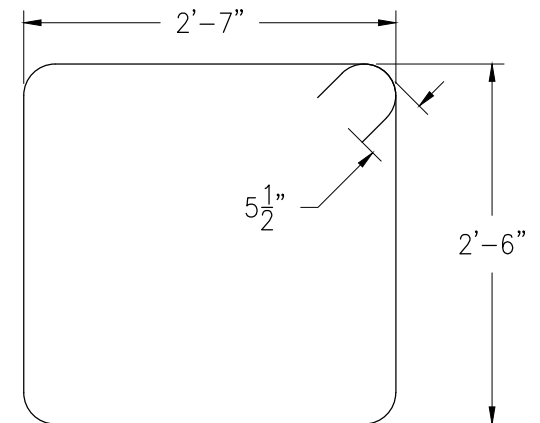

**BARS S2**  
SCALE 3/4" = 1'-0"

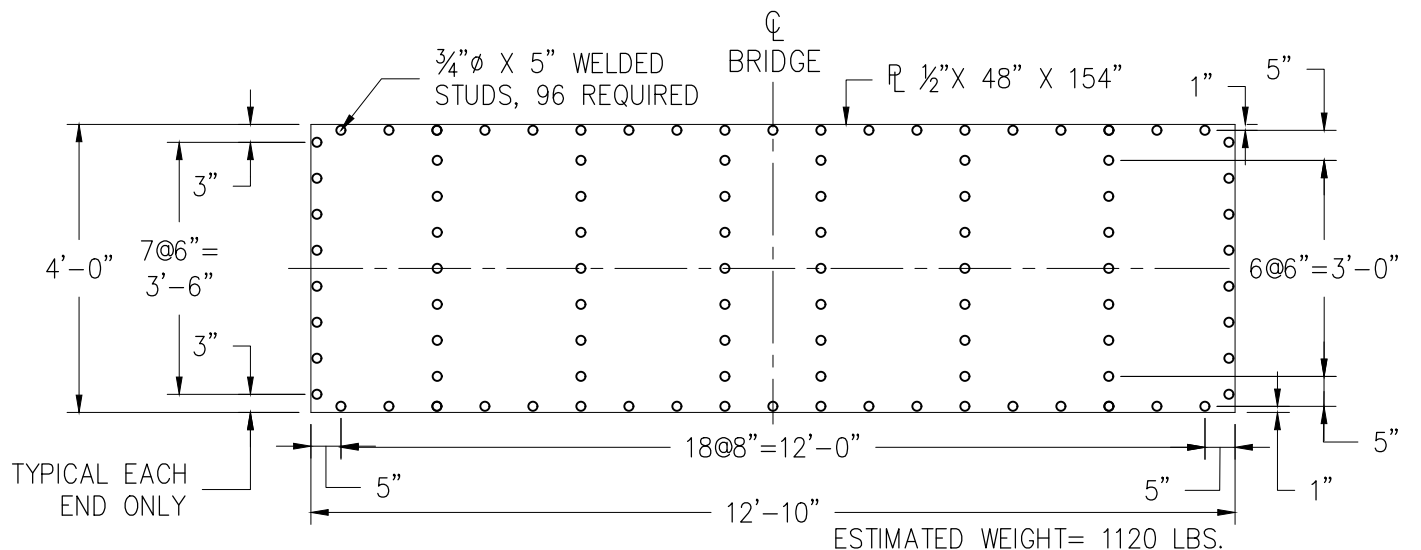

**EMBEDDED PLATE DETAIL**  
SCALE 3/8" = 1'-0"

- NOTES:
1. PROVIDE 3/4 INCH CHAMFER FOR ALL CONCRETE CORNERS.
  2. THE CONCRETE BENT CAP MUST BE CONSTRUCTED SO THE TOP AND BOTTOM SURFACES ARE PARALLEL. THE TOP AND BOTTOM SURFACES MUST BE FINISHED FLAT WITH NO VARIANCES TO EXCEED 1/8 INCH UNDER A 10 FOOT LONG STRAIGHT EDGE. ALL VARIATIONS TO THIS REQUIREMENT MUST BE CORRECTED TO THE SATISFACTION OF ALASKA RAILROAD PRIOR TO ACCEPTANCE.
  3. EXTRA ATTENTION SHOULD BE DIRECTED TO PLACEMENT OF THE DYWIDAGS SO THAT THEY ARE CONSISTENT WITH THE DRAWINGS.
  4. ALASKA RAILROAD STOCK NO. 312970

**ALASKA RAILROAD CORPORATION**  
ENGINEERING SERVICES  
P.O. BOX 107500, ANCHORAGE, ALASKA 99510-7500

PROJECT : **STANDARD 28 FOOT CONCRETE BALLAST DECK (CBD)**

TITLE : **TWO ROW PILE CAP PLAN AND DETAILS**

DESIGNED BY: ARRC	SCALE : AS NOTED	AFE NO.:
DRAWN BY: ARRC	DATE : FEB 2019	ACAD FILE:
CHECKED BY: CDR		DWG NO. <b>12</b> OF <b>15</b>
APPROVED BY: BAL		

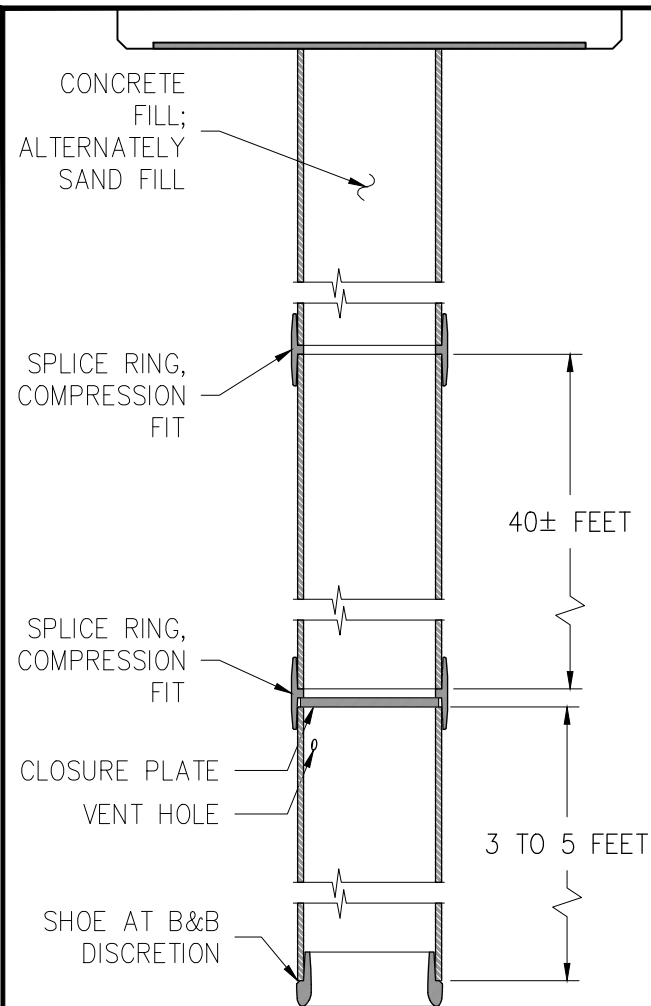

**TYPICAL PIPE PILE DETAIL**

NO SCALE

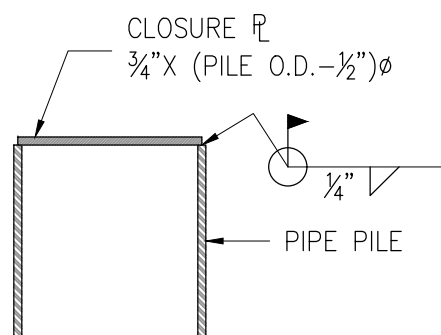

**CLOSURE PLATE DETAIL**

SCALE: 1" = 1'-0"

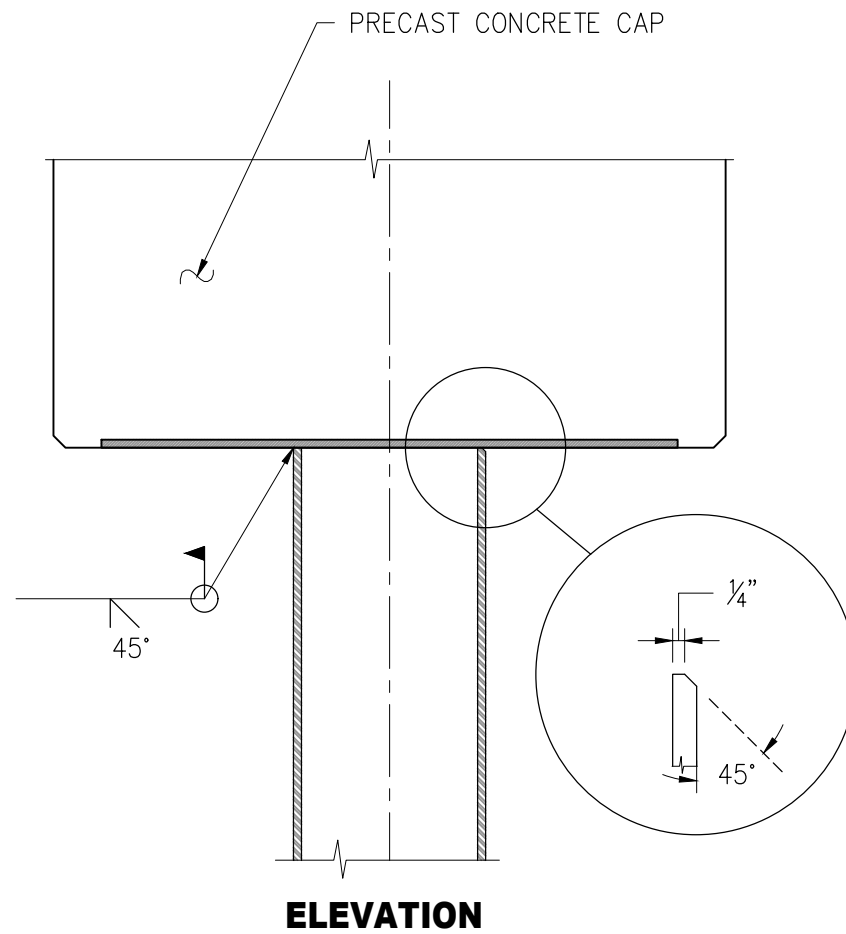

**PIPE PILE CONNECTION DETAIL**

SCALE: 1" = 1'-0"

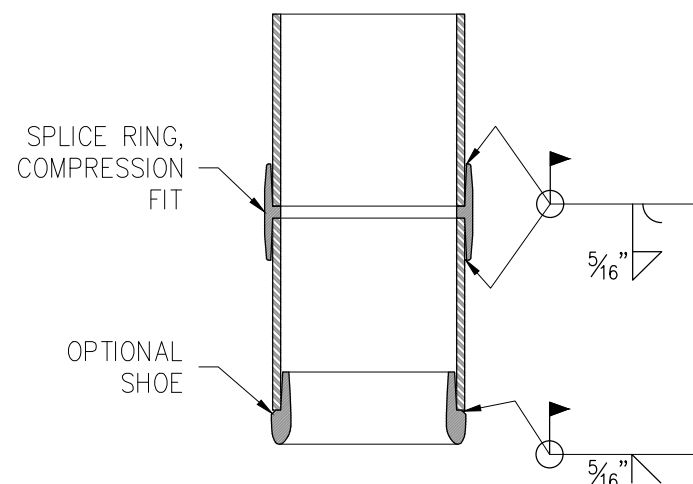

**SPLICE AND SHOE DETAIL**

SCALE: 1" = 1'-0"

**NOTES:**

1. CONSIDER MAKING PIPE TO CAP PERIMETER WELD IN OPPOSING QUADRANTS TO CONTROL HEAT BUILD-UP AND LIMIT RISK OF DAMAGING CAP.
2. PILING SHALL MEET ONE OF THE FOLLOWING SPECIFICATIONS:
  - A. ASTM A 53 GRADE B:  
HYDROSTATIC TEST REQUIREMENTS ARE WAIVED.  
NONDESTRUCTIVE ELECTRIC TEST REQUIREMENTS ARE WAIVED.
  - B. ASTM A 252 GRADE 2:  
CHEMICAL COMPOSITION MUST MEET THE REQUIREMENTS OF ASTM A53, GRADE B, OR API SPECIFICATION 5L, PRODUCT SPECIFICATION LEVEL 1, GRADE X52,  
  
OR,  
BIDDERS MUST ESTABLISH WELDING PROCEDURES BY QUALIFICATION IN ACCORDANCE WITH AWS D1.1. WELDING PROCEDURES SHALL INCLUDE FULL PENETRATION WELDS FOR FIELD AND SHOP PILE SPLICES. PROCEDURES SHALL BE FURNISHED WITHIN 15 DAYS OF THE BID DUE DATE.
  - C. ANSI/API SPECIFICATION 5L, PSL 1, GRADE X52;
  - D. ANSI/API SPECIFICATION 2B, FABRICATED STRUCTURAL STEEL PIPE;
2. PIPE MUST BE FABRICATED FROM A LISTED BASE METAL PLATE FOUND IN D1.1 UNDER TUBULAR STRUCTURES.
3. MILL CERTIFICATION DOCUMENTATION IS REQUIRED. IN ADDITION, CHEMICAL COMPOSITION DOCUMENTATION IS REQUIRED FOR PILING SUPPLIED UNDER THE SPECIFICATION FOR ASTM A252 GRADE 2.
4. PILING SHALL HAVE SQUARE OR BEVEL ENDS.
5. SPLICE RINGS ARE COMPRESSION FIT MECHANICAL SPLICER TO MATCH PILE DIAMETER AND COATING WHERE PROVIDED.
6. DRIVE SHOES ARE INSIDE FLANGE AND OPEN ENDED MATCHING PILE DIAMETER WITH MILL FINISH.
7. GALVANIZING, WHEN SPECIFIED, SHALL BE IN ACCORDANCE WITH ASTM A 123.
8. INDIVIDUAL PIPE LENGTHS MUST BE DELIVERED WITHIN A TOLERANCE OF PLUS OR MINUS 12 INCHES FROM THE LENGTH SPECIFIED. THE TOTAL LENGTH FURNISHED OF EACH SHALL NOT BE LESS THAN THE SUMMATION OF THE NOMINAL SPECIFIED LENGTH TIMES THE NUMBER REQUIRED.

<b>ALASKA RAILROAD CORPORATION</b> ENGINEERING SERVICES P.O. BOX 107500, ANCHORAGE, ALASKA 99510-7500		
PROJECT :		
<b>STANDARD 28 FOOT CONCRETE BALLAST DECK (CBD)</b>		
TITLE:		
<b>PIPE PILE BENTS MISCELLANEOUS DETAILS</b>		
DESIGNED BY: ARRC	SCALE : AS NOTED	AFE NO.:
DRAWN BY: ARRC	DATE : FEB 2019	ACAD FILE:
CHECKED BY: CDR		DWG NO. <b>13</b> OF <b>15</b>
APPROVED BY: BAL		

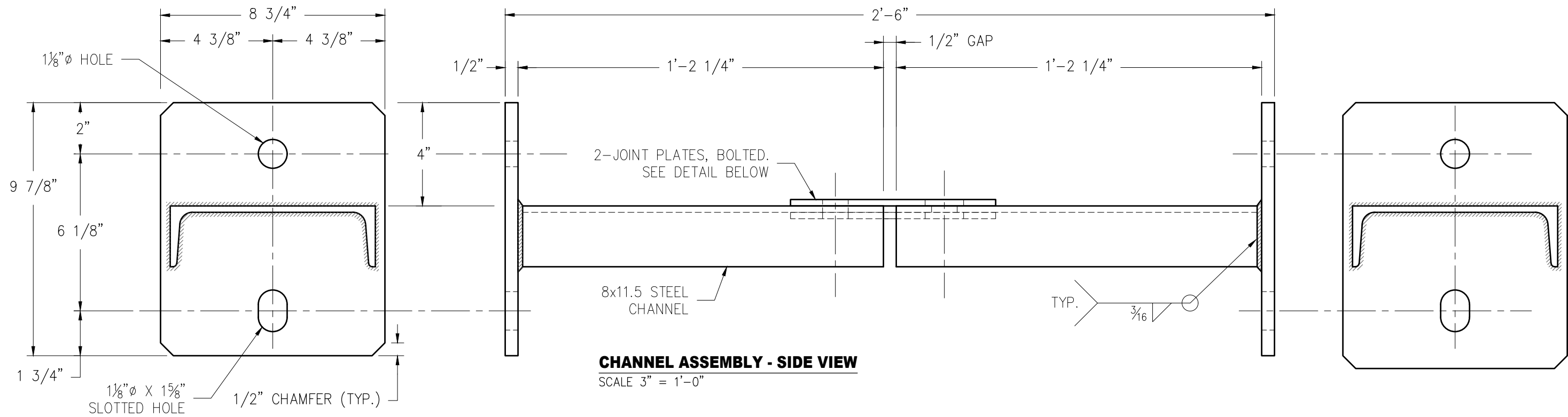

**BASE PLATE PLAN**

SCALE 3" = 1'-0"

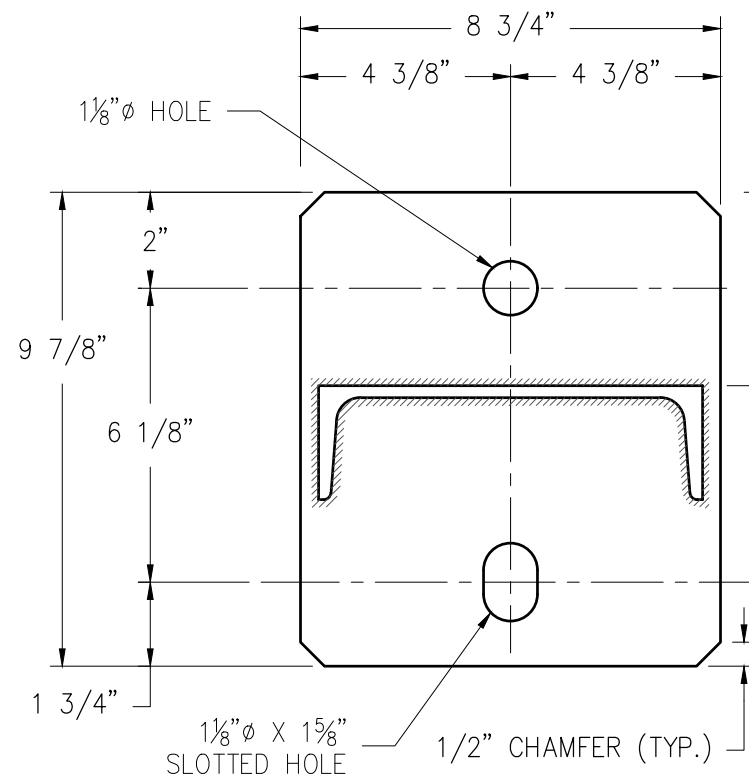

**CHANNEL ASSEMBLY - SIDE VIEW**

SCALE 3" = 1'-0"

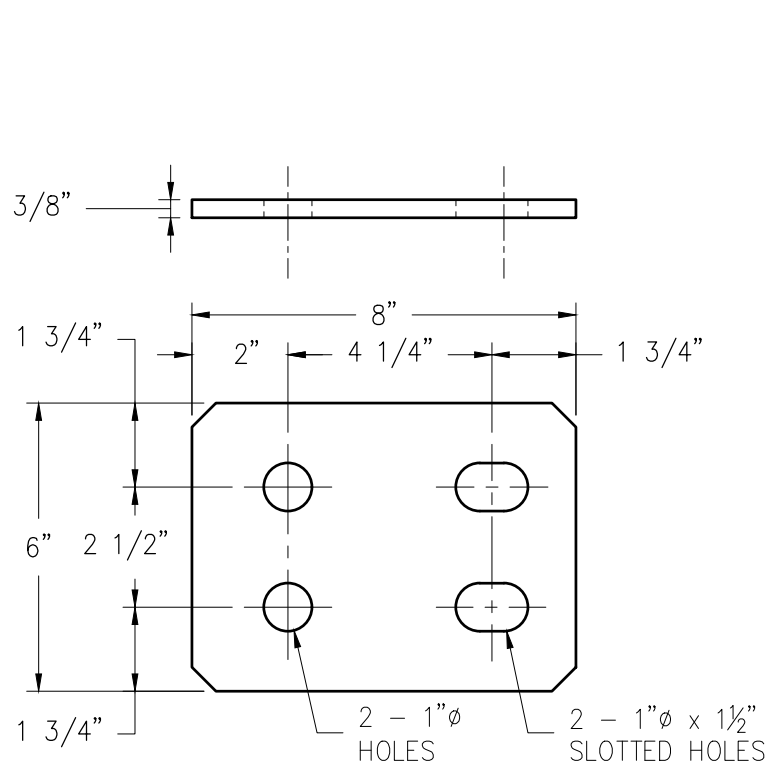

**JOINT PLATE DETAIL**

SCALE 3" = 1'-0"

NOTE: 2 REQUIRED PER ASSEMBLY

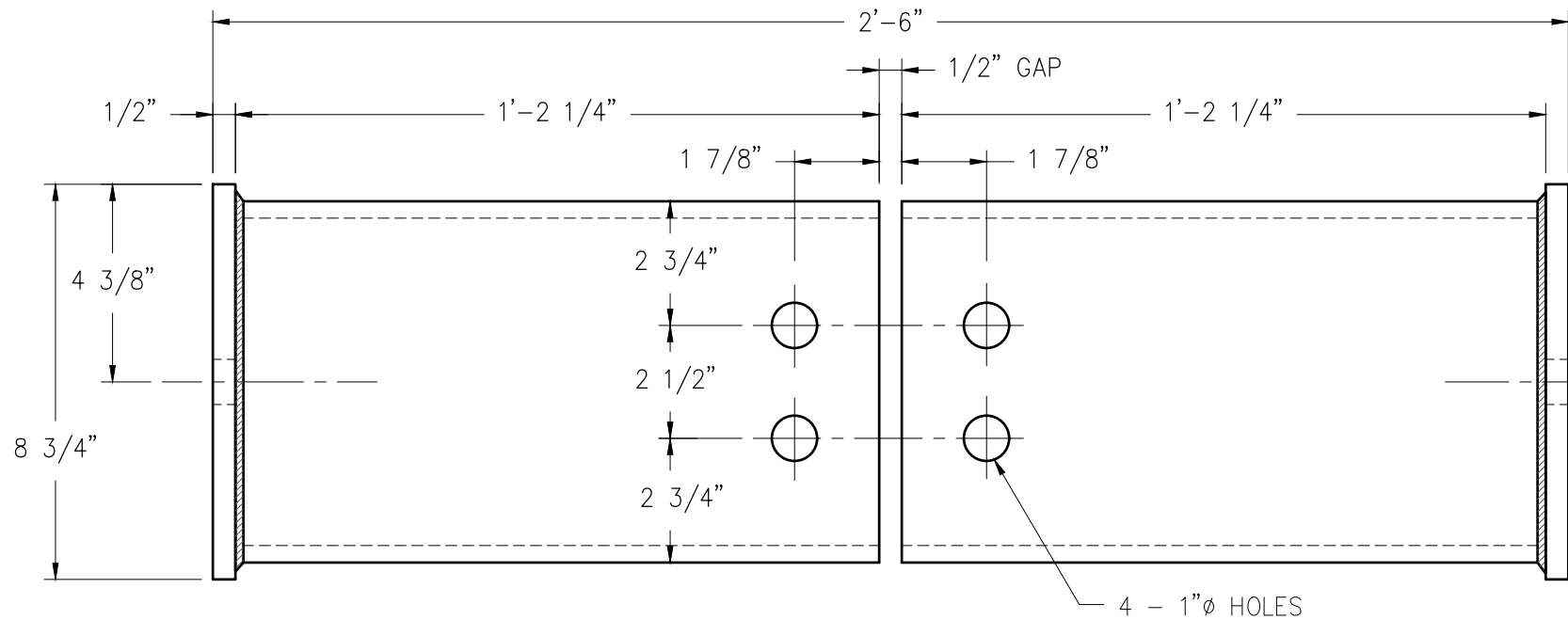

**CHANNEL ASSEMBLY - PLAN VIEW**

SCALE 3" = 1'-0"

**NOTES:**

1. MATERIAL ASTM A36, SIZE AS SPECIFIED.
2. SPRAY METALIZED OR HOT DIP GALVANIZED.
3. THREE (3) ASSEMBLIES PER SPAN.

 <b>ALASKA RAILROAD CORPORATION</b> ENGINEERING SERVICES P.O. BOX 107500, ANCHORAGE, ALASKA 99510-7500		
PROJECT :		
<b>STANDARD 28 FOOT CONCRETE BALLAST DECK (CBD)</b>		
TITLE:		
<b>BRIDGE IN TANGENT DIAPHRAGM DETAIL</b>		
DESIGNED BY: RJT	SCALE : AS NOTED	AFE NO.:
DRAWN BY: DxD	DATE : FEB 2019	ACAD FILE:
CHECKED BY: CDR		DWG NO. <b>14</b> OF <b>15</b>
APPROVED BY: BAL		

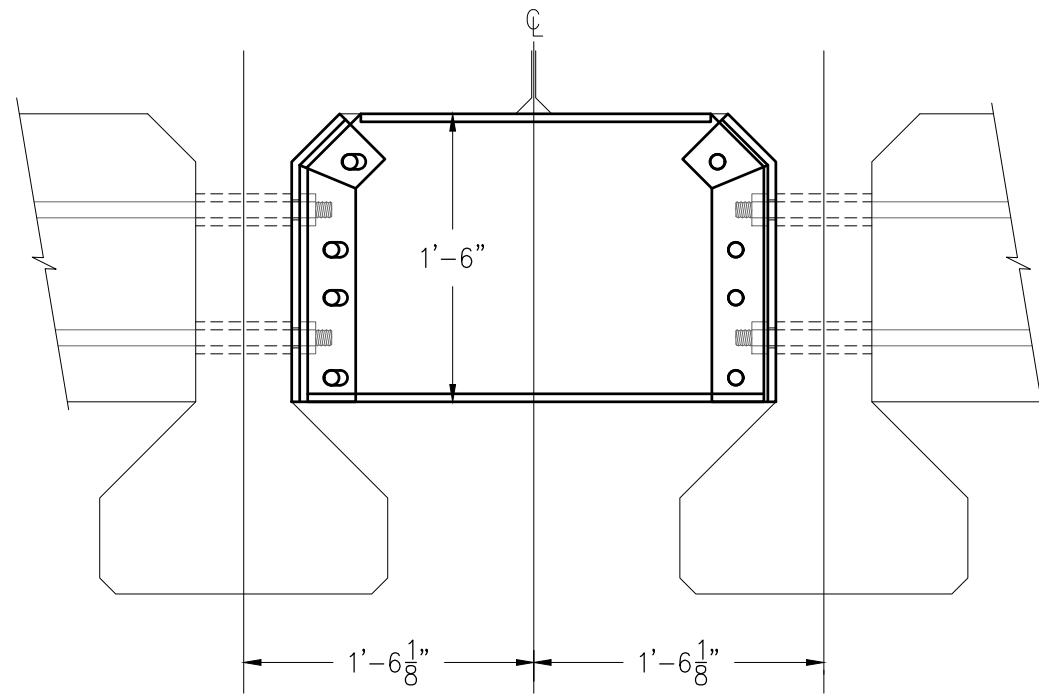

**BRIDGE DIAPHRAGM**  
SCALE 1" = 1'

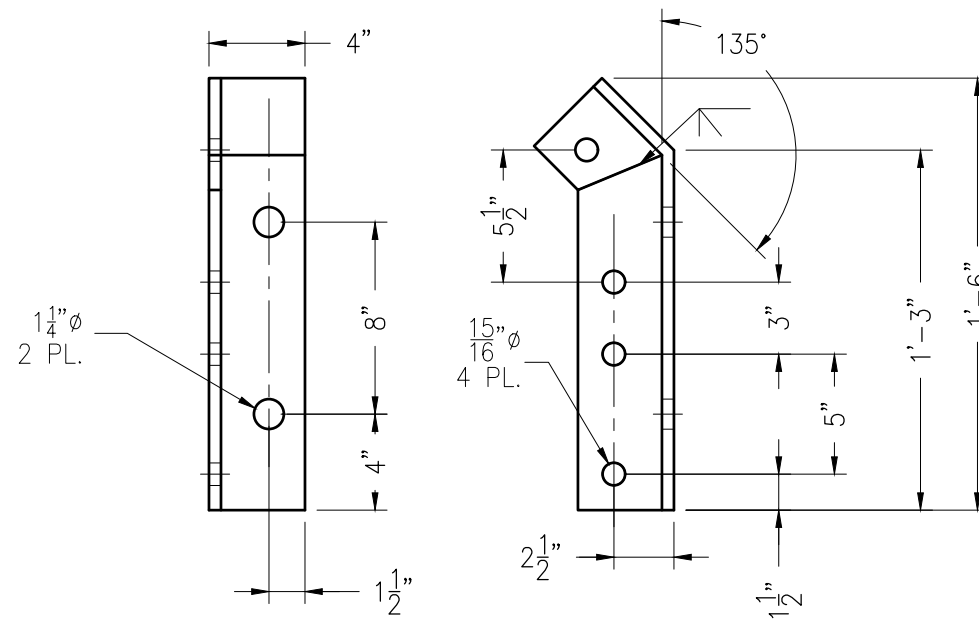

**L4x4x1/2 DETAIL**  
SCALE 1 1/2" = 1'-0"

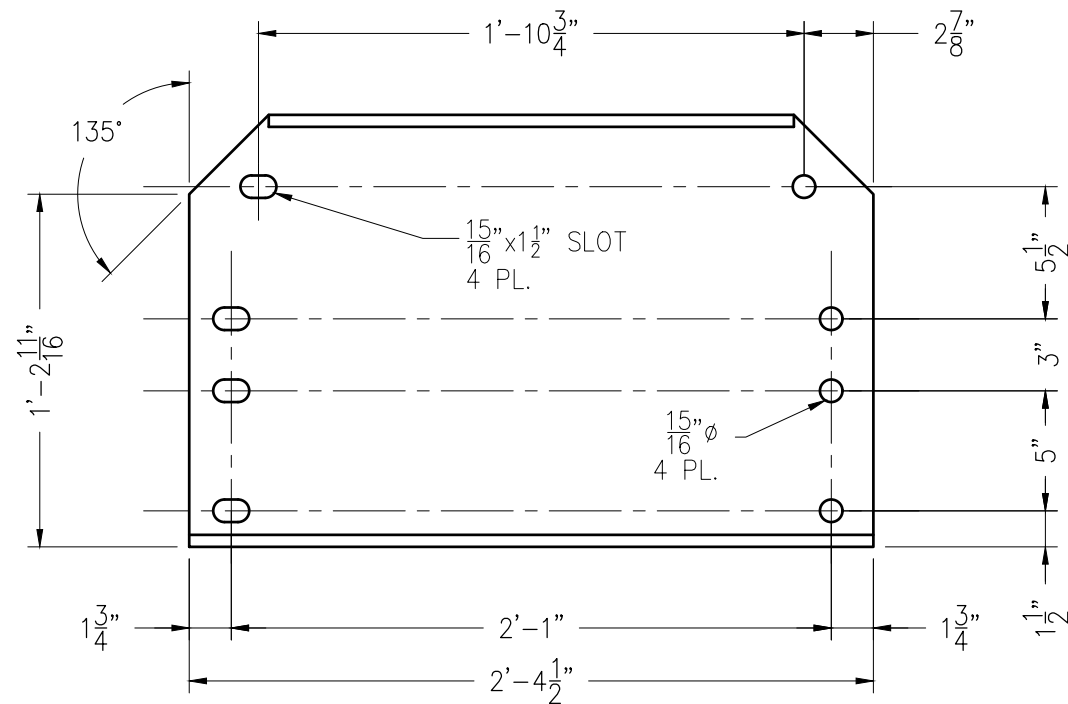

**MC18x45.8 DETAIL**  
SCALE 1 1/2" = 1'-0"

**NOTES:**

1. MATERIAL ASTM A36, SIZE AS SPECIFIED, SPRAY METALIZED OR HOT DIP GALVANIZED.
2. THREE (3) ASSEMBLIES PER SPAN:  
1 EA. MC18x45.8 C-CHANNEL AS SHOWN  
1 EA. L4x4x1/2 ANGLE AS SHOWN  
1 EA. L4x4x1/2 ANGLE OPPOSITE-HAND AS SHOWN
3. BENT-PLATE EQUIVALENT MAY BE SUBSTITUTED FOR MC18x45.8 C-CHANNEL ON ARRC APPROVAL.

 <b>ALASKA RAILROAD CORPORATION</b> ENGINEERING SERVICES P.O. BOX 107500, ANCHORAGE, ALASKA 99510-7500		
PROJECT :		
<b>STANDARD 28 FOOT CONCRETE BALLAST DECK (CBD)</b>		
TITLE:		
<b>BRIDGE IN CURVE DIAPHRAGM DETAIL</b>		
DESIGNED BY: <u>RJT</u>	SCALE : AS NOTED	AFE NO.:
DRAWN BY: <u>DxD</u>	DATE : FEB 2019	ACAD FILE:
CHECKED BY: <u>CDR</u>		DWG NO. <b>15</b> OF <b>15</b>
APPROVED BY: <u>BAL</u>		